



SNOWPLOWS

November 1, 2007
Lit. No. 27375, Rev. 01

MECHANIC'S GUIDE



SNOWPLOWS

Featuring the

**Insta-Act® XLS™ Hydraulic System &
Isolation Module Light System**

⚠ CAUTION

Read this manual before servicing the snowplow.

TABLE OF CONTENTS

Introduction	4	3-Port Module Electrical	28
Preface	4	Electrical & Hydraulic Schematics	32
Recommended Tools	4	Legend	32
Available Service Items	4	Electrical Schematic – 4-Port Module	33
Safety Information	5	Electrical Schematic – 3-Port Module	34
System Overview	8	Hydraulic Schematic	35
Blade, A-Frame & Headgear	8	Raise	36
Blade Spring Replacement Tool (PN 20043)	8	Lower	38
Headlamp Beam Aiming	9	Angle Right	40
Vehicle Lighting Check	10	Angle Left	42
Hydraulic	11	Scoop	44
XLS™ Insta-Act® Hydraulic System Specifications	11	Retract	46
Hydraulic Fitting and Hose Installation	12	Right Wing Out	48
Orifice Plate	14	Right Wing In	50
Hydraulic Unit Components	15	Left Wing Out	52
Hydraulic Component Installation	16	Left Wing In	54
Valve Location	17	Hold in Raised Position	56
Cartridge Valves	18	Striking An Object While Plowing Forward – DS	57
Relief Valves	19	Striking An Object While Plowing Forward – PS	58
Electrical	20	Striking an Object w/Wings in Scoop Position While Plowing Forward	59
Wiring – 4-Port Module	20	Low Beam Headlamps with Snowplow Connected to Vehicle (4-Port Module)	60
Wiring – 3-Port Module	21	High Beam Headlamps with Snowplow Connected to Vehicle (4-Port Module)	61
Electrical Assembly	22	Low Beam Headlamps with Snowplow Connected to Vehicle (3-Port Module)	62
Cover and Final Assembly	23	High Beam Headlamps with Snowplow Connected to Vehicle (3-Port Module)	63
Controls	24	Troubleshooting Guide Table of Contents	64
General Information	24		
XLS Fish-Stik® Hand-Held Control	25		
Theory of Operation	27		
Snowplow Hydraulics	27		
4-Port Module Electrical	27		

INTRODUCTION

PREFACE

This guide has been prepared to assist the trained mechanic in the service of FISHER® snowplows. It also provides safety information and recommendations. We urge all mechanics to read this manual carefully before attempting to service the FISHER snowplow equipment covered by this guide.

Service of your FISHER snowplow equipment is best performed by your local Fisher Engineering outlet. They know your snowplow best and are interested in your complete satisfaction.

RECOMMENDED TOOLS

- Long/Slender Needle Nose Pliers
- Flat Screwdriver
- 12V Test Light
- Torque Wrench
- Allen Wrench Set including 3/8" Allen wrench
- Combination Std. Wrench Set
- 1/4" Drive Ratchet Set w/6" ext.
- 3/8" Drive Ratchet Set
- Deep Socket: 7/8"
- Standard Socket: 1"
- 11/16" Tappet Wrench
- 1-1/2" Socket & Wrench
- Angle Head Wrenches: 15° & 60°
- Digital Volt/Ohmmeter
- Ammeter
- Pressure Test Kit
- Flashlight
- Pick Set
- Hammer
- Pencil Magnet
- TORX® Drivers: T20 & T30
- Automotive Blade-Type Fuses: 7.5- & 15-Amp (4-Port Module)
- Mini Fuses: 4-Amp (All) 10-Amp (3-Port Module)
- Vacuum Pump w/3/8" NPT Barbed Fitting
- 3/8" NPT Plug

AVAILABLE SERVICE ITEMS

- Motor Bearing Sleeve Repair Kit: PN 64589
(Requires 3/8-24 x 4 Hex Cap Screw, not included.)
- Isolation Module Tester: PN 26470-1
- Isolation Module Tester Adapter: PN 29294
(Required if *not* using 26470-1 Tester; not included with 26470 Tester.)
- Pressure Test Kit: PN 56686
(Requires adapter fitting, not included. See Pump Pressure Test.)
- Spring Removal Tool: PN 20043
- Diagnostic Harness: PN 29290-1
- Pump Shaft Seal Repair Kit: PN 28856
(Requires 1/4-28 x 4-1/2 Hex Cap Screw, not included.)

TORX® is a registered (®) trademark of Textron, Inc.

SAFETY INFORMATION

SAFETY DEFINITIONS

⚠ WARNING

Indicates a potentially hazardous situation that, if not avoided, could result in death or serious personal injury.

⚠ CAUTION

Indicates a potentially hazardous situation that, if not avoided, may result in minor or moderate injury. It may also be used to alert against unsafe practices.

NOTE: Indicates a situation or action that can lead to damage to your snowplow and vehicle or other property. Other useful information can also be described.

WARNING/CAUTION AND INSTRUCTION LABELS

Become familiar with and inform users about the warning and instruction labels on the back of the blade.

NOTE: If labels are missing or cannot be read, see your sales outlet.

Warning and Caution Label

⚠ WARNING

LOWER BLADE WHEN VEHICLE IS PARKED.

DO NOT EXCEED GVWR OR GAWR INCLUDING BLADE AND BALLAST.

REMOVE BLADE ASSEMBLY BEFORE PLACING VEHICLE ON HOIST.

⚠ CAUTION

READ OWNER'S MANUAL BEFORE OPERATING OR SERVICING SNOWPLOW.

TRANSPORT SPEED SHOULD NOT EXCEED 45 MPH. FURTHER REDUCE SPEED UNDER ADVERSE TRAVEL CONDITIONS.

PLOWING SPEED SHOULD NOT EXCEED 10 MPH.

SEE YOUR SALES OUTLET/WEB SITE FOR SPECIFIC VEHICLE APPLICATION RECOMMENDATIONS.

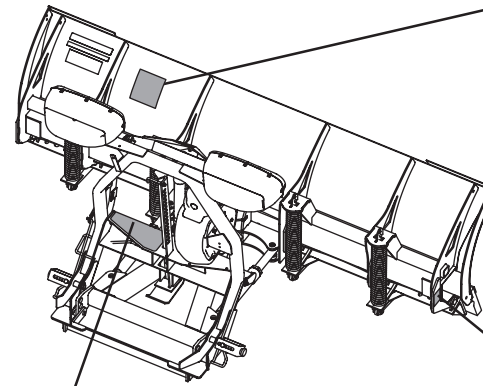

Instruction Label

ATTACH
DETACH

1. Push **Pin Release Handle** down to pull out **Connecting Pins**.
2. Drive vehicle slowly to engage **Pushplates** into **Attachment Arms**.
3. Stand in front of blade. Fully raise **Pin Release Handle** to release **Connecting Pins**.
4. Push **Headgear** toward vehicle to allow **Connecting Pins** to fully engage **Pushplates**. If unable to push **Headgear** from in front of blade, stand in front of **Headgear** on driver side and push **Headlamp Bracket**.
5. Pull out **Jack Lock**. Push **Pin Release Handle** into **Stop**.
6. While holding **Jack Lock** out, use **Jack Handle** to raise **Jack** fully. Release **Jack Lock**.
7. Attach all electrical connectors.

U.S. Patents 4,999,935; 5,353,530; 5,420,480; 6,253,470; 6,944,978; RE 35,700; CAN Patent 2,060,425; and other patents pending.

Read Owner's Manual For Complete Instructions

1. Place control in Lower/Float to put blade down.
2. Pull and hold **Jack Lock** out. **Jack** will drop to ground. Then pull **Pin Release Handle** away from **Stop** and **Jack Lock**. Release **Jack Lock**. Verify **Jack** is locked by trying to lift **Jack**.
3. Stand in front of blade. While pushing **Headgear** toward vehicle with left hand, push **Pin Release Handle** down to disengage **Connecting Pins**. Make sure **Connecting Pins** are fully retracted. If unable to push **Headgear** from in front of blade, stand in front of **Headgear** on driver side and push **Headlamp Bracket**.
4. Detach all electrical connectors.

27451

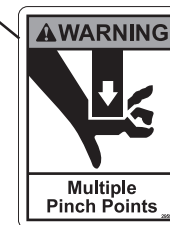

SAFETY INFORMATION

SAFETY PRECAUTIONS

Improper installation and operation could cause personal injury, and/or equipment and property damage. Read and understand labels and the Owner's Manual before installing, operating, or making adjustments.

⚠ WARNING

Lower blade when vehicle is parked. Temperature changes could change hydraulic pressure, causing the blade to drop unexpectedly or damaging hydraulic components. Failure to do this can result in serious personal injury.

⚠ WARNING

The driver shall keep bystanders clear of the blade when it is being raised, lowered or angled. Do not stand between the vehicle and the blade or within 8 feet of a moving blade. A moving or falling blade could cause personal injury.

⚠ WARNING

Keep hands and feet clear of the blade and A-frame when attaching or detaching the snowplow. Moving or falling assemblies could cause personal injury.

⚠ WARNING

Do not exceed GVWR or GAWR including blade and ballast. The rating label is found on the driver-side vehicle door cornerpost.

⚠ WARNING

To prevent accidental movement of the blade, always turn the ON/OFF switch to OFF whenever the snowplow is not in use. The control indicator light will turn off.

⚠ WARNING

Remove blade assembly before placing vehicle on hoist.

⚠ CAUTION

Refer to the current Kit Selection Guide for minimum vehicle recommendations and ballast requirements.

HYDRAULIC SAFETY

⚠ WARNING

Hydraulic fluid under pressure can cause skin injection injury. If you are injured by hydraulic fluid, get medical attention immediately.

- Always inspect hydraulic components and hoses before using. Replace any damaged or worn parts immediately.
- If you suspect a hose leak, DO NOT use your hand to locate it. Use a piece of cardboard or wood.

FUSES

The FISHER® electrical and hydraulic systems contain several blade-style automotive fuses. If a problem should occur and fuse replacement is necessary, the replacement fuse must be of the same type and amperage rating as the original. Installing a fuse with a higher rating can damage the system and could start a fire. Fuse Replacement, including fuse ratings and locations, is located in the Maintenance section of the Owner's Manual.

PERSONAL SAFETY

- Remove ignition key and put the vehicle in park or in gear to prevent others from starting the vehicle during installation or service.
- Wear only snug-fitting clothing while working on your vehicle or snowplow.
- Do not wear jewelry or a necktie, and secure long hair.
- Wear safety goggles to protect your eyes from battery acid, gasoline, dirt and dust.
- Avoid touching hot surfaces such as the engine, radiator, hoses and exhaust pipes.
- Always have a fire extinguisher rated BC handy, for flammable liquids and electrical fires.

FIRE AND EXPLOSION

⚠ WARNING

Gasoline is highly flammable and gasoline vapor is explosive. Never smoke while working on vehicle. Keep all open flames away from gasoline tank and lines. Wipe up any spilled gasoline immediately.

Be careful when using gasoline. Do not use gasoline to clean parts. Store only in approved containers away from sources of heat or flame.

SAFETY INFORMATION

VENTILATION

⚠ WARNING

Vehicle exhaust contains lethal fumes. Breathing these fumes, even in low concentrations, can cause death. Never operate a vehicle in an enclosed area without venting exhaust to the outside.

BATTERY SAFETY

⚠ CAUTION

Batteries normally produce explosive gases which can cause personal injury. Therefore, do not allow flames, sparks or lit tobacco to come near the battery. When charging or working near a battery, always cover your face and protect your eyes, and also provide ventilation.

Batteries contain sulfuric acid which burns skin, eyes and clothing.



Disconnect the battery before removing or replacing any electrical components.

TORQUE CHART

⚠ CAUTION

Read instructions before assembling. Fasteners should be finger tight until instructed to tighten according to torque chart. Use standard methods and practices when attaching snowplow including proper personal protective safety equipment.

Recommended Fastener Torque Chart (Ft.-Lb.)

Size	 SAE Grade 2	 SAE Grade 5	 SAE Grade 8
1/4-20	6	9	13
5/16-18	11	18	28
3/8-16	19	31	46
3/8-24	24	46	68
7/16-14	30	50	75
1/2-13	45	75	115
9/16-12	66	110	165
5/8-11	93	150	225
3/4-10	150	250	370
7/8-9	150	378	591
1-8	220	583	893

Metric Grade 8.8 (Ft.-Lb.)

Size	Torque	Size	Torque
M 6	7	M 12	60
M 8	17	M 14	95
M 10	35	M 16	155

These torque values apply to fasteners except those noted in the instruction.

SYSTEM OVERVIEW – BLADE, A-FRAME & HEADGEAR

BLADE SPRING REPLACEMENT TOOL (PN 20043)

⚠ CAUTION
Servicing the trip springs without special tools and knowledge could result in personal injury.

1. Insert the threaded rod in through the hole in the channel weldment. Be sure the threaded hole in the tab on the rod is nearest to the channel.
2. Place the assembly on to the top anchor above the spring as illustrated. Be sure to place the spring bar in between the tabs on the rod. Insert the 1/2" x 1-1/2" cap screw through the outside tab, through the hole in the spring bar, and tighten into the threaded hole.
3. Drop the 1/2" flat washer over the threaded rod and fasten the nut to the threaded rod. Tighten the nut until the spring bar is raised enough to insert the pin through the pin hole. Center the pin within the hole.
4. Loosen the nut to lower the spring bar. Remove the spring tool assembly by removing the 1/2" cap screw.
5. Remove the spring from the blade by removing the bolt from the bottom of the spring bar.
6. Insert the new spring with the spring bar up through the top anchor on the blade. Fasten the bottom of the spring bar to the anchor on the trip edge with the previously removed fasteners. Tighten.
7. Repeat Steps 1 and 2 above.
8. Repeat Step 3 above, except remove the pin from the spring bar.
9. Repeat Step 4 above.

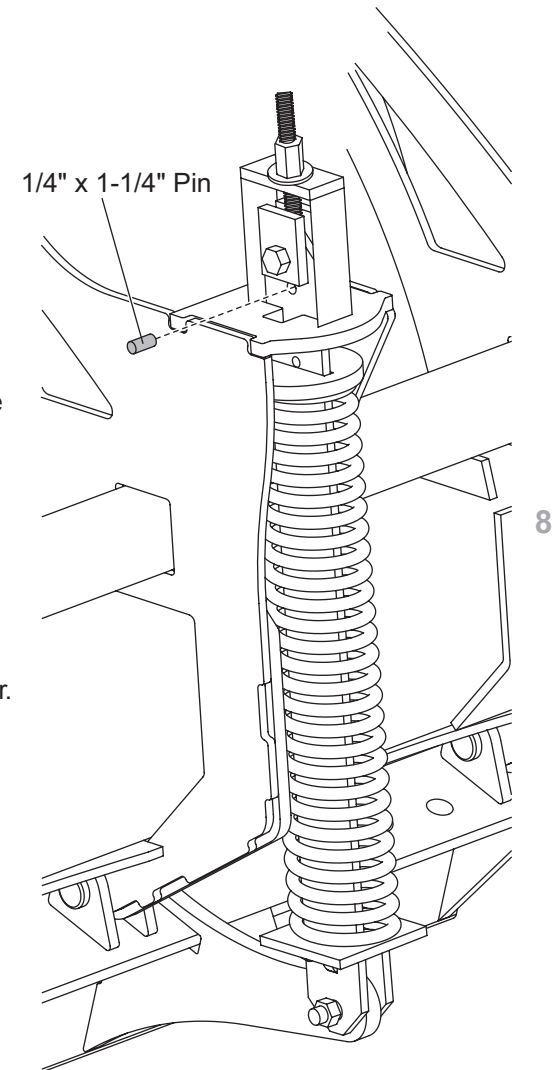
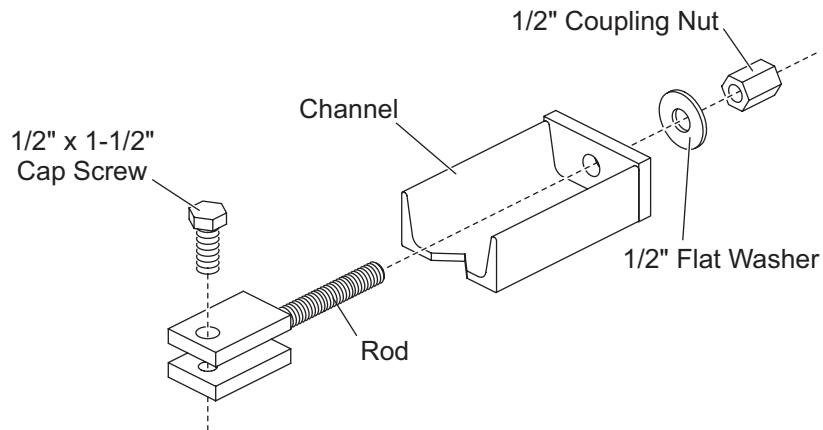

Excerpts taken from Removable Spring Tool Installation Instructions (Lit. No. 6486, Rev. 02).

SYSTEM OVERVIEW – BLADE, A-FRAME & HEADGEAR

HEADLAMP BEAM AIMING

Torque headlamp fasteners to 45 ft-lb once correct visual aim is achieved.

1. Place vehicle on a level surface 25 feet in front of a matte-white screen, such as a garage door. The screen should be perpendicular both to the ground and to the vehicle centerline.
2. The vehicle should be equipped for normal operation. The snowplow blade should be in place and in raised position. Below are steps listed by the Society of Automotive Engineers (SAE) pertinent to headlamp aiming in specification #SAE J599d.
3. Prepare vehicle for headlamp aim or inspection. Before checking beam aim, the inspector will:
 - a. Remove ice or mud from under fenders.
 - b. Set tire inflation pressures to the values specified on vehicle information label.
 - c. Check springs for sag or broken leaves.
 - d. See that there is no load in the vehicle other than the driver and ballast as specified in the Kit Selection Guide.
 - e. Check functioning of any automatic vehicle leveling systems and specific manufacturer's instructions pertaining to vehicle preparation for headlamp aiming.
 - f. Clean lenses.
 - g. Check for bulb burnout and proper beam switching.
 - h. Stabilize suspension by rocking vehicle sideways.
4. Mark (or tape) the vertical centerline of the snowplow headlamps and the vertical centerline of the vehicle on the screen. Mark the horizontal centerline of the snowplow headlamps on the screen (distance from ground to snowplow headlamp centers).
5. Align the top edge of the high intensity zone of the snowplow lower beam below the horizontal centerline and the left edge of the high intensity zone on the vertical centerline for each snowplow headlamp. (Refer to diagram.)

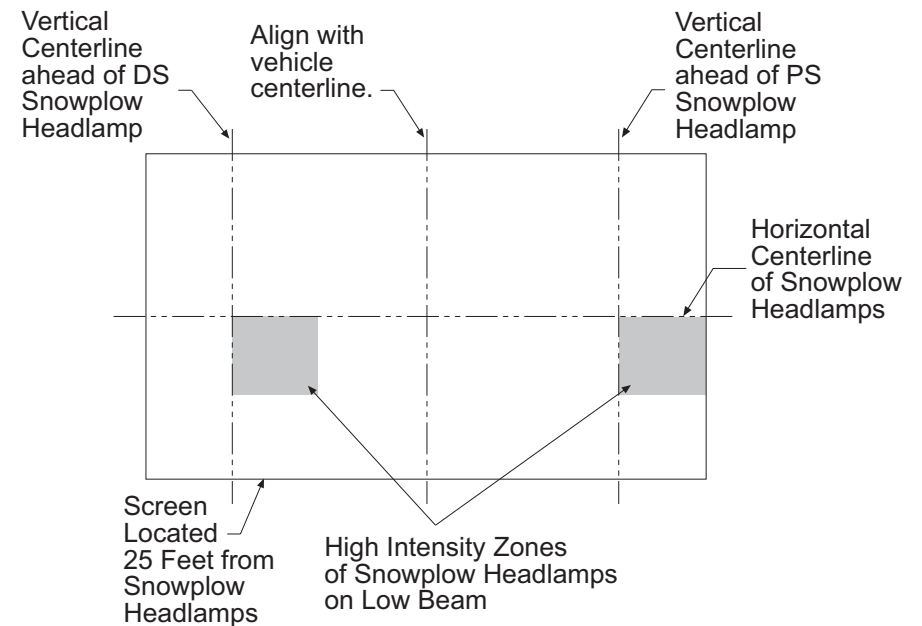

SYSTEM OVERVIEW – BLADE, A-FRAME & HEADGEAR

VEHICLE LIGHTING CHECK

1. Verify the operation of all vehicle front lighting prior to connecting the snowplow harness.
2. Check the operation of the snowplow lights with snowplow mounted to vehicle and all harnesses connected.

Turn signals and parking lamps

Parking lamps ON:

- Both vehicle and snowplow parking lamps should be ON at the same time.

Driver-side turn signal ON:

- Both vehicle and snowplow driver-side turn signal lamps should flash at the same time.

Passenger-side turn signal ON:

- Both vehicle and snowplow passenger-side turn signal lamps should flash at the same time.

Headlamps

Move vehicle headlamp switch to the "ON" position. Connecting and disconnecting the snowplow lighting harness plug should

switch the lights between vehicle and snowplow as follows:

Snowplow lighting harness DISCONNECTED:

- Vehicle headlamps should be ON.
- Snowplow headlamps should be OFF.

Snowplow lighting harness CONNECTED:

- Snowplow headlamps should be ON.
- Vehicle headlamps should be OFF.

Dimmer switch should toggle headlamps between high and low beams. The high beam indicator on the dash should light when headlamps are placed in high beam.

Daytime Running Lamps (DRLs)

An operational check of the vehicle and snowplow DRLs will depend on the vehicle model, vehicle DRL system and type of Isolation Module installed. Due to the variations in the OEM DRL systems and the different

Isolation Module options available, checking the functionality of the snowplow DRLs will depend on the type of module installed on the vehicle.

With headlamp switch OFF, activate the vehicle DRLs.

Snowplow lighting harness DISCONNECTED:

- Vehicle DRLs should be ON.
- Snowplow headlamps should be OFF.

Snowplow lighting harness CONNECTED and vehicle in DRL mode:

- Check snowplow DRL function per the type of Isolation Module installed.

Hand-Held Control

The snowplow plugs **do** need to be connected to the vehicle harness connectors. The control indicator light should light whenever the control ON/OFF switch and the ignition (key) switches are both in the "ON" position.

3. Connect all snowplow and vehicle harnesses. Raise the snowplow and aim snowplow headlamps according to the Snowplow Headlamp Beam Aiming instructions included with the headlamps and any state or local regulations.
4. Check aim of vehicle headlamps with snowplow removed.

CAUTION

On 2-plug electrical systems, plug covers shall be used whenever snowplow is disconnected. Vehicle Battery Cable is 12-volt unfused source.

5. When the snowplow is removed from the vehicle, install plug covers on the vehicle battery cable and lighting harness. Insert the snowplow battery cable and lighting harness into the cable boot on the snowplow.

SYSTEM OVERVIEW – HYDRAULIC

XLS™ Insta-Act® HYDRAULIC SYSTEM SPECIFICATIONS

Fisher Engineering's Insta-Act hydraulic system delivers fast and uniform speed for lifting and angling. The system raises the blade in two seconds, and all angling functions are less than five seconds.

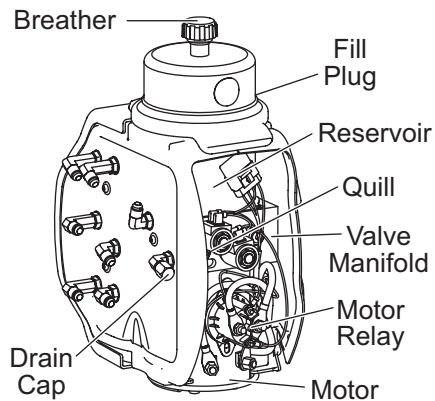

Relief Valve Settings

- Pump Relief Valve (1)
2250 psi
2-1/2 turns CCW from fully seated
- Primary Wing Relief Valves (2)
1500 psi
See Relief Valve Inspection and Adjustment Section
- Secondary Wing Relief Valves (2)
1700 psi
See Relief Valve Inspection and Adjustment Section

System Capacity

⚠ CAUTION
Do not mix different types of hydraulic fluid. Some fluids are not compatible and may cause performance problems and product damage.

- Unit Reservoir = 1-3/4 Quarts
- System Total = 2-3/8–2-3/4 Quarts

Hydraulic Fluid

Use FISHER® EZ Flow Hydraulic Fluid to –40°F (–40°C) or other fluid conforming to military specification MIL-H-5606A, such as Mobil Aero HFA or Shell AeroShell® Fluid 4. Use of other than these recommended fluids may cause poor hydraulic system performance and damage to internal components.

Motor/Hydraulic Specifications

12V DC with +/- connection
4.5" dia. 1.5 kw motor
2200–2300 psi pump relief valve
4000 psi plowing relief valve
1500 & 1700 psi wing plowing relief valves
.000652 GAL/REV pump
Hydraulic Hose 1/4 SAE 100R1 and 3/8 SAE 100R17

Electrical System (Approximate)

- Solenoid Coil Resistance = 7 ohm at room temperature
- Solenoid Coil Amp Draw = 1.5 Amps
- Motor Relay Coil Resistance = 13.5 ohm @ 25° C
- Motor Relay Amp Draw = 0.7 Amp
- Maximum Motor Amp Draw = 250 Amps over relief at 2250 psi
- Switch Accessory Lead Draw = 0.75 Amp

Fastener Torque

Pump Cap Screws	5/16-18 x 2-1/2	150-160 in-lb
Motor Terminals (+ and –)	5/16-18 Nut	50-60 in-lb
Motor to Manifold Cap Screws	1/4-20 x 6-1/4	30-40 in-lb
Reservoir Screws	#10-24 x 5/16	30-35 in-lb
Solenoid Valves	7/8 Hex Head	19-21 ft-lb
Coil Nuts	3/4 Hex-Head Jam Nut	40-60 in-lb
Cover Screws	1/4-20 x 1/2 Shoulder Screw	60-80 in-lb
SAE O-Ring Plugs	1/8 or 5/32 Internal Hex	55-65 in-lb
Hydraulic Unit Mount Bolts	3/8-16 x 1	25-33 ft-lb
Check Valves	7/8 Hex Head	19-21 ft-lb
Secondary to Primary Manifolds	1/4-20 x 3	10-13 ft-lb
Motor Relay Small Terminals	10-32 Nut	15 in-lb max
Motor Relay Large Terminals	5/16-24 Nut	35 in-lb max
Motor Relay Mount Screws	1/4-20 x 1/4	90-100 in-lb
Plow Module Mount Screws	1/4-20 x 5/8	60-70 in-lb
Angle Ram Piston Locknuts		100-120 ft-lb
Angle Ram Gland Nuts		150-180 ft-lb

Vehicle Control Harness Fuses

4-Port Module (Automotive Blade-Type)

- Park/Turn = 15 Amp
- Control = 7.5 Amp

3-Port Module (Mini)

- Control and Module = 10 Amp

Hydraulic Unit Harness Fuses

All (Mini)

- 4 Amp

AeroShell® is a registered (®) trademark of Shell Oil Company.

SYSTEM OVERVIEW – HYDRAULIC

HYDRAULIC FITTING AND HOSE INSTALLATION

Do not use thread sealant/tape on hoses and fittings. This could damage the product. Install all fittings into rams and hydraulic unit using the following procedure and fitting orientation illustrations:

1. Remove the plug from ram or manifold port. Use a rag to catch residual fluid when removing the manifold plugs.

2. Turn the jam nut on the fitting as far back as possible.
3. Lubricate the O-ring with clean hydraulic fluid.
4. Install the hexagonal orifice plate under each of the two wing rod fittings as shown below.

The slot in the orifice plate must face the manifold. Installing the orifice plates backwards will cause blade wings to "chatter" when retracting.

5. Screw the fitting into the port by hand as far as it will go. The washer should contact the port face and shoulder of the jam nut threads.
6. Unscrew the fitting to proper position, no more than one full turn.

7. Use one wrench to hold the fitting body in position and tighten the jam nut with another wrench until the washer again contacts the port face. Tighten 1/8–1/4 turn to lock the fitting in place.

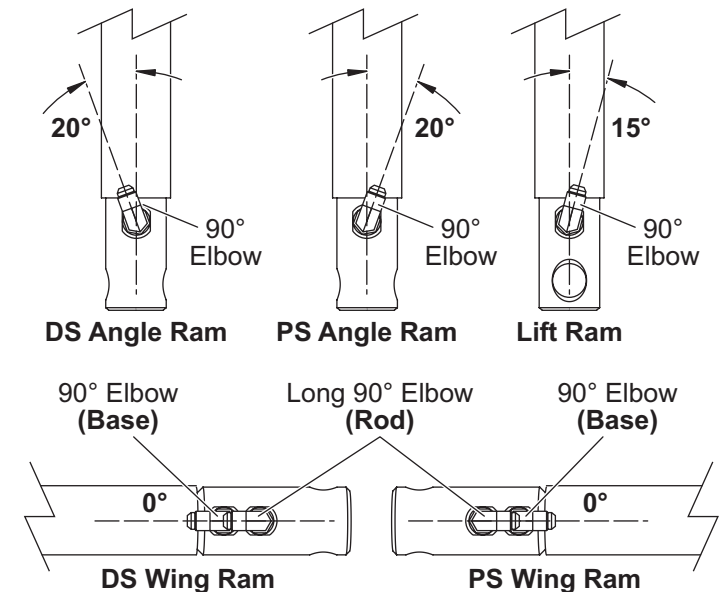
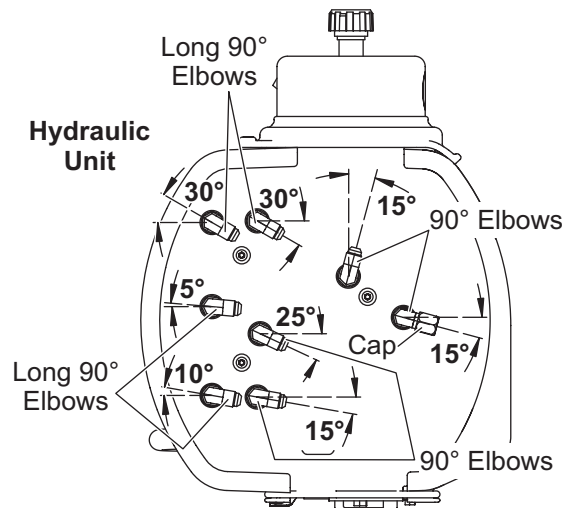
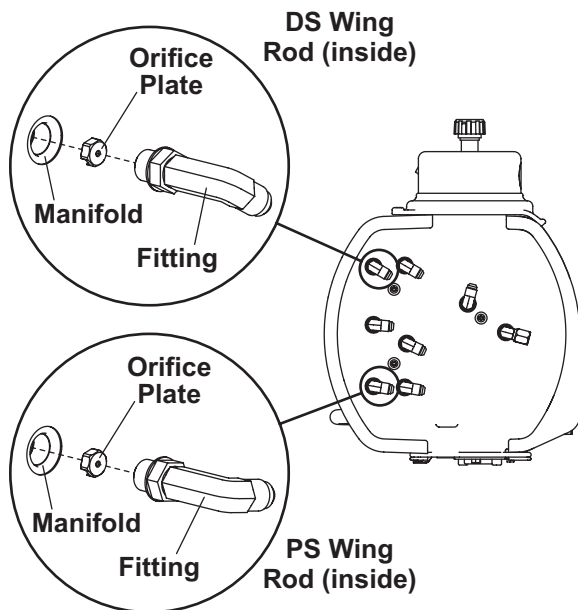

Excerpts taken from XLS™ Snowplow Installation Instructions (Lit. No. 50579, Rev. 01).

SYSTEM OVERVIEW – HYDRAULIC

HYDRAULIC FITTING AND HOSE INSTALLATION

Use the following procedure and illustrations to install hoses.

Do not use thread sealant/tape on hoses and fittings. This could damage product.

1. Apply the caution label to each wing hose near the wing ram fitting, as shown below.

CAUTION

CAUTION! Verify hoses from cylinder are connected to correct manifold port or cylinder will bend. The extend port is closest to the rod and the retract port is closest to the base.

Wrap label around hose and press ends together.

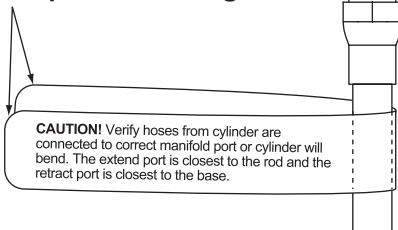

CAUTION
Assembling a hose to the incorrect wing ram port can result in permanent damage to the ram.

2. Attach all hoses to fittings, routing hoses as shown. Leave the hoses finger tight at this time.

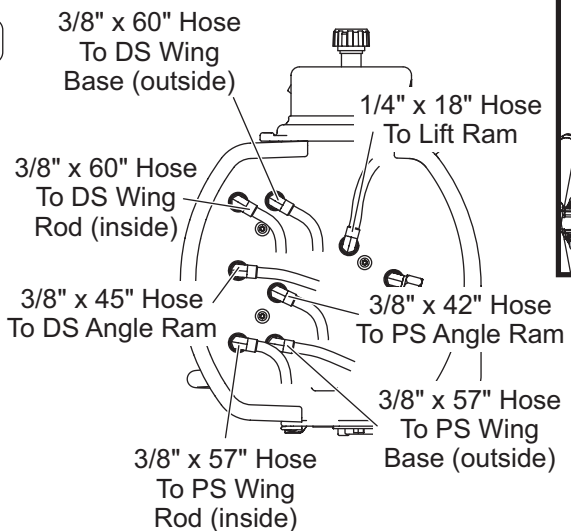

3. Apply two protective hose wraps to each group of hoses from the fitting side of the hydraulic unit around and behind the jack leg and hydraulic unit and over the headgear to the front. Apply one hose wrap to each set of wing ram hoses beginning near the wing ram fittings.

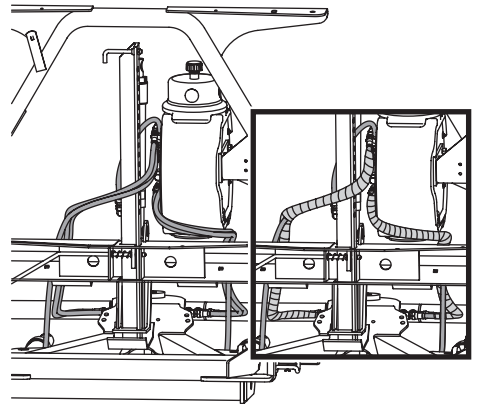
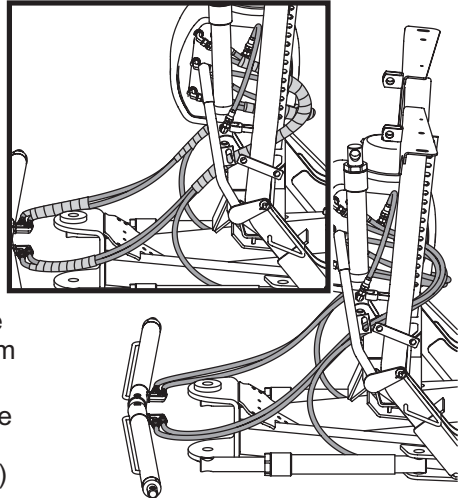

4. Using a wrench to hold the hose end in position, tighten all hose fittings 1/8–1/4 turn past finger tight.

Excerpts taken from XLS™ Snowplow Installation Instructions (Lit. No. 50579, Rev. 01).

SYSTEM OVERVIEW – HYDRAULIC

ORIFICE PLATE

Each of the two wing rod ports on the manifold contains an orifice plate beneath the fitting. This plate is a single piece with a hole in the center and a slot on one face. It has enough room to move slightly back and forth, depending on the flow of hydraulic fluid.

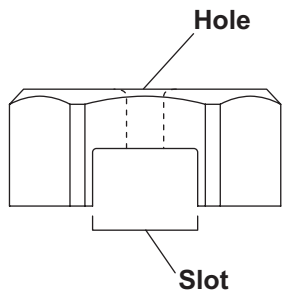

Wing Out & Scoop

When either wing is extended by using the WING OUT function, or when both are extended using the SCOOP function, hydraulic fluid

pushes the plate in towards the manifold. The slot in the face of the orifice plate allows fluid to flow around the plate, as well as through the center hole, unrestricted.

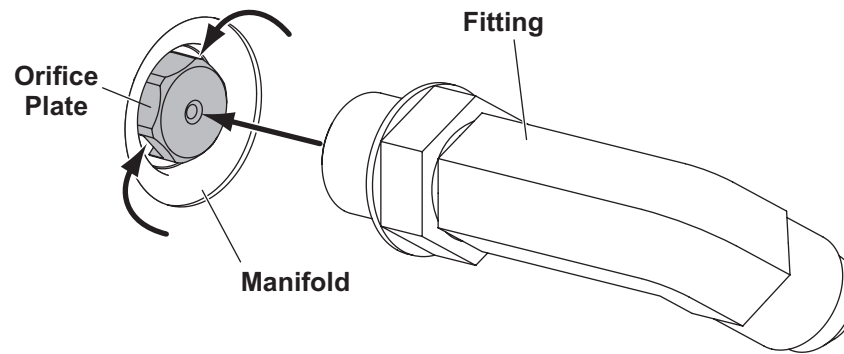

WING OUT & SCOOP

Wing In & Retract

When either wing is retracted by using the WING IN function, or when both are retracted using the RETRACT function, hydraulic fluid pushes the plate out against the fitting. This causes the flow to be restricted to the center hole only.

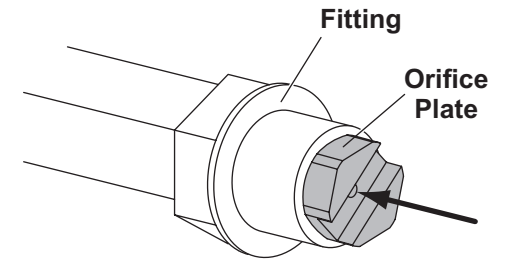

WING IN & RETRACT

SYSTEM OVERVIEW – HYDRAULIC

HYDRAULIC UNIT COMPONENTS

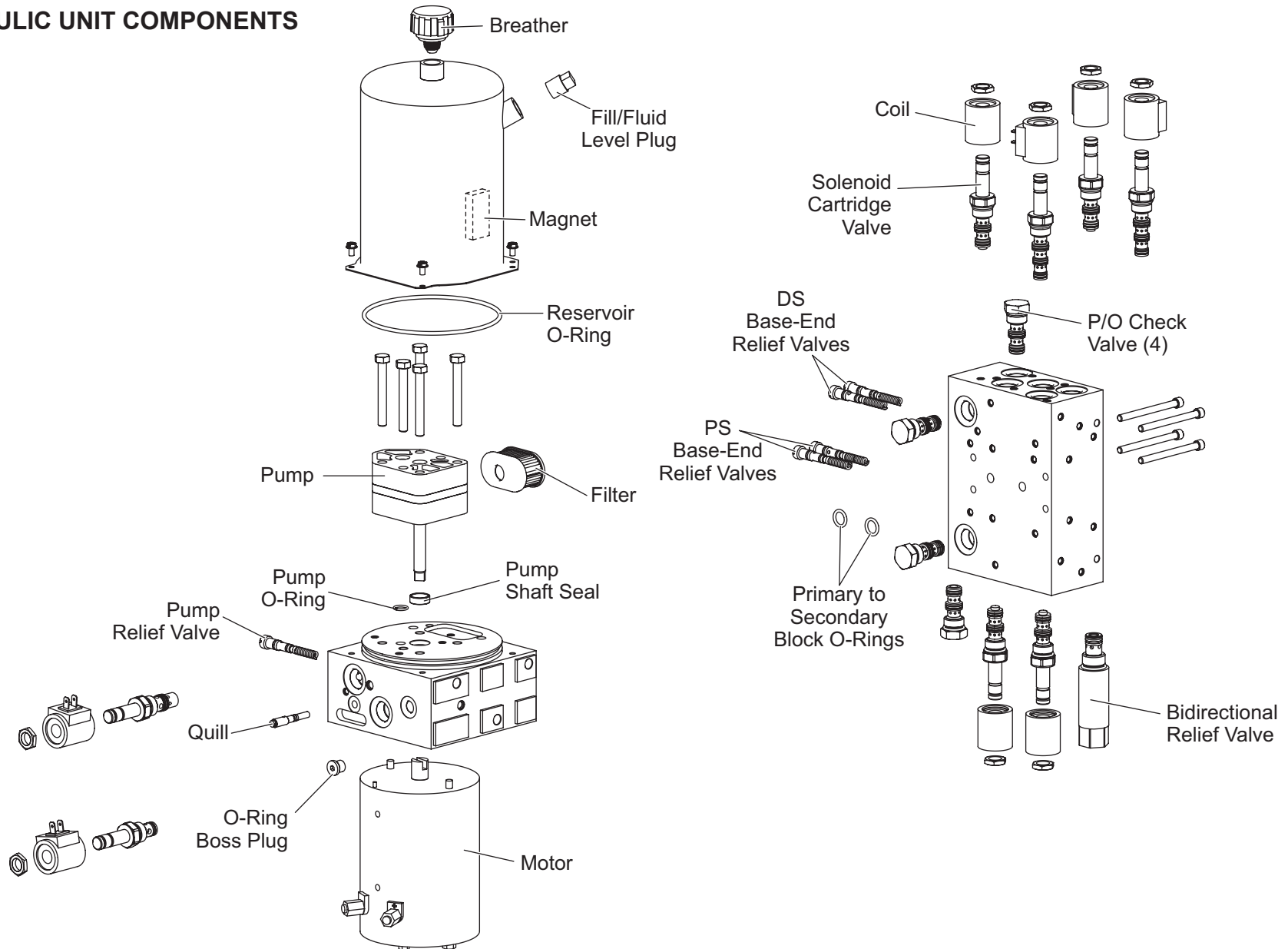

SYSTEM OVERVIEW – HYDRAULIC

HYDRAULIC COMPONENT INSTALLATION

Ram Seal Installation

1. Lubricate the seals and O-rings with hydraulic fluid.

NOTE: Placing the part in warm fluid will facilitate installation.

2. Install the seals and O-rings in the **exact** orientation as shown.
3. **For single-acting rams:** Slide the gland nut over the split bearing end of the rod to prevent damaging the seals.

For double-acting rams: Slide the gland nut over the threaded end of the rod to prevent damaging the seals.

4. Carefully reassemble the ram.
5. Insert a 0.012" feeler gauge between the front surface of the cylinder tube face and the hex of the gland nut. Tighten the gland nut until it is snug against the feeler gauge.
6. Remove the feeler gauge, and tighten the gland nut an additional **1/4 turn**. This adjustment procedure will provide a torque of 150–180 ft-lb.

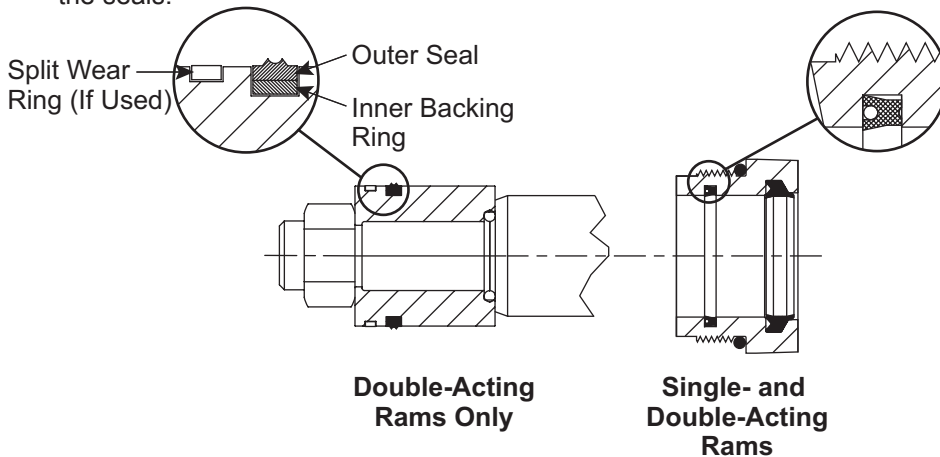

Cartridge & Check Valve Removal

It is possible to remove cartridges and check valves from a hydraulic unit without draining the hydraulic fluid from the reservoir.

1. Install the Diagnostic Harness (PN 29290-1) following the instructions included with the kit.
2. Cycle through the control functions twice to remove the pressure in the hydraulic unit.
3. Slowly remove the breather from the top of the hydraulic unit.
4. Either (a) completely drain reservoir and skip to Step 9 or (b) proceed with instructions on removing hydraulic components without completely draining reservoir.

5. Install a 3/8" barb fitting into the top of the reservoir tank.
6. Attach a hand-operated vacuum pump to the barb fitting.
7. Using the vacuum pump, pull a vacuum of approximately 5"–10" Hg.
8. You should now be able to remove cartridges and check valves from the hydraulic unit with minimal fluid loss. Maintain the vacuum until the replacement cartridge/check valve has been installed. Once the replacement part has been installed, release the vacuum and remove the 3/8" barb fitting.
9. Reinstall the breather and remove the 29290-1 Diagnostic Harness according to the instructions included with the kit.

Excerpts taken from Gland Nut Ram Seal Kits Service Literature (Lit. No. 28944, Rev. 01).

SYSTEM OVERVIEW – HYDRAULIC

VALVE LOCATION

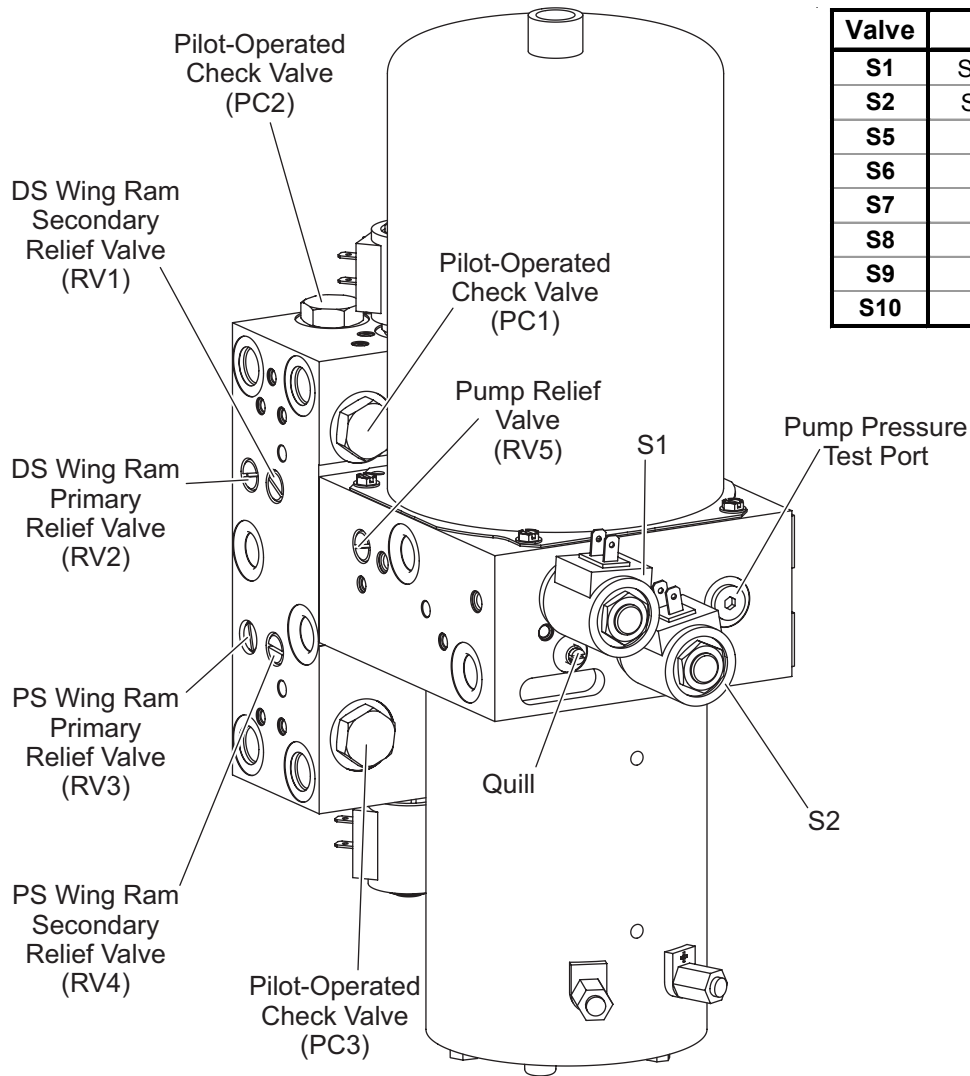

Valve	Type	Wire Color
S1	SVCV08-20	White
S2	SV08-2004	Green
S5	SV08-45	Black
S6	SV08-41	Yellow
S7	SV08-30	Brown
S8	SV08-30	Gray
S9	SV08-30	White
S10	SV08-30	Blue

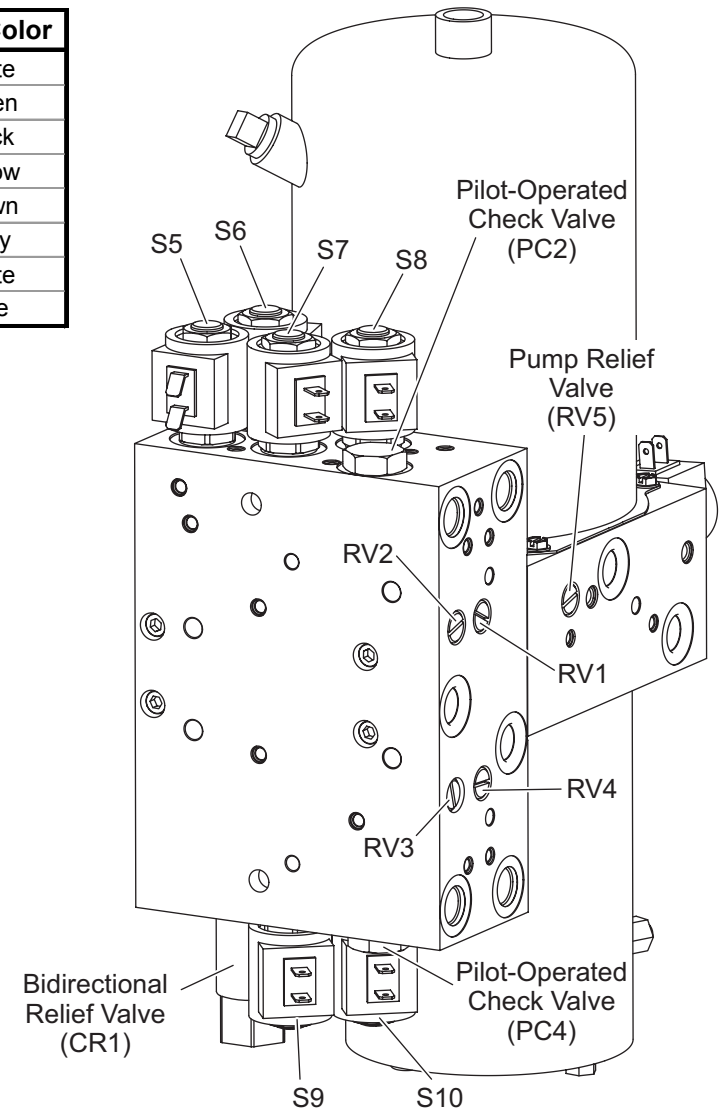









SYSTEM OVERVIEW – HYDRAULIC

CARTRIDGE VALVES

The XLS™ snowplow Insta-Act® hydraulic system performs 10 blade movement functions.

All functions require the vehicle ignition (key) switch to be in the run or accessory position and the power to be activated on the snowplow cab control.

Nine of the ten hydraulic functions require energizing the electric motor and opening solenoid cartridge valves. The LOWER function does not energize the motor but requires opening of one valve.

BLADE MOVEMENT		RAISE ↑	LOWER ↓	ANGLE RIGHT 	ANGLE LEFT 	SCOOP 	RETRACT 	(RIGHT) WING OUT 	(RIGHT) WING IN 	(LEFT) WING OUT 	(LEFT) WING IN 
MOTOR	M	ON		ON	ON	ON	ON	ON	ON	ON	ON
SVCV08-20	S1	ON									
SV08-2004	S2		ON								
SV08-45	S5			ON							
SV08-41	S6				ON						
SV08-30	S7						ON				ON
SV08-30	S8					ON				ON	
SV08-30	S9						ON		ON		
SV08-30	S10					ON		ON			

SYSTEM OVERVIEW – HYDRAULIC

RELIEF VALVES

When all cartridge valves are closed, hydraulic fluid is trapped in the cylinder by the solenoid cartridge valves, P/O check valves and base-end relief valves.

When a blade wing in the scoop position contacts an object while plowing, the force of the impact increases hydraulic pressure in the base end of the ram. When pressure exceeds 1500 psi, the cylinder's primary relief valve opens, allowing hydraulic fluid to move from the base end to the rod end of that same cylinder.

When the pressure exceeds 1700 psi, the cylinder's secondary relief valve opens, allowing the remaining hydraulic fluid to flow back to the reservoir.

NOTE: See Relief Valve Inspection and Adjustment Section for service.

NOTE: See "Striking an Object While Plowing" Schematics for Details.

Relief Valve	Approx. Pressure (psi)	# of Turns Out (ccw) from Fully Seated
A (Qty 2)	1500	†
B (Qty 2)	1700	†
C (Qty 1)	2250*	2-1/2

* See the Pump Pressure Test Section for details.

† See the Relief Valve Inspection and Adjustment Section for details.

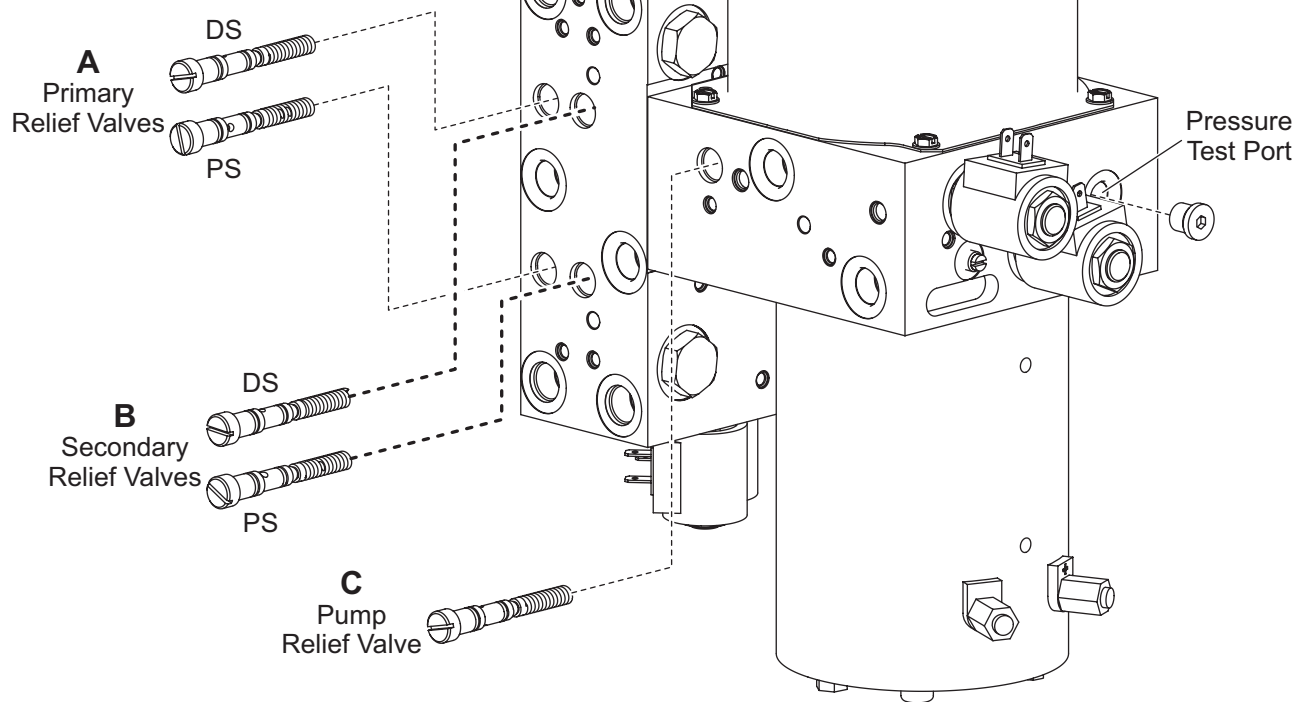

SYSTEM OVERVIEW – ELECTRICAL

WIRING – 4-PORT MODULE

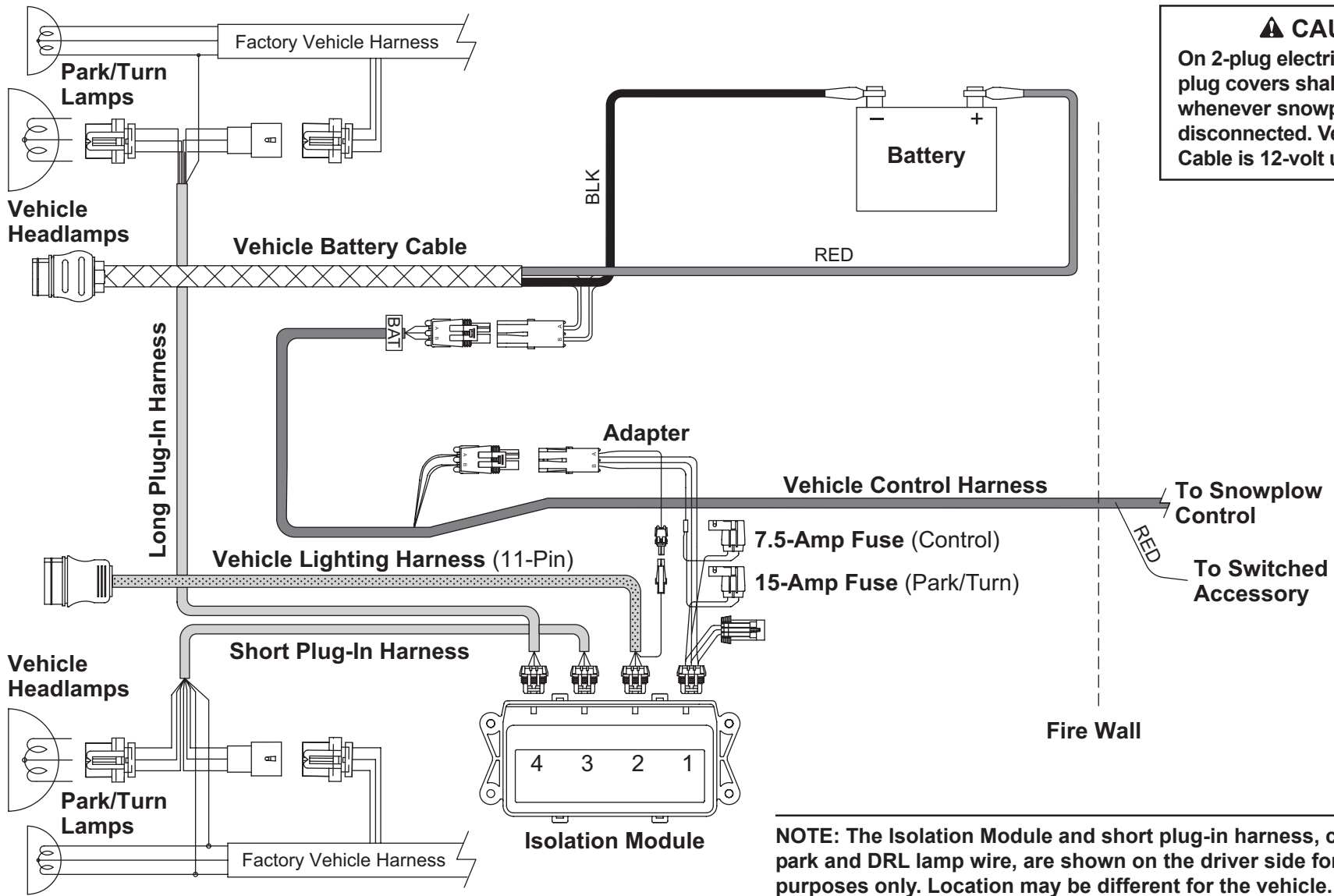

SYSTEM OVERVIEW – ELECTRICAL

WIRING – 3-PORT MODULE

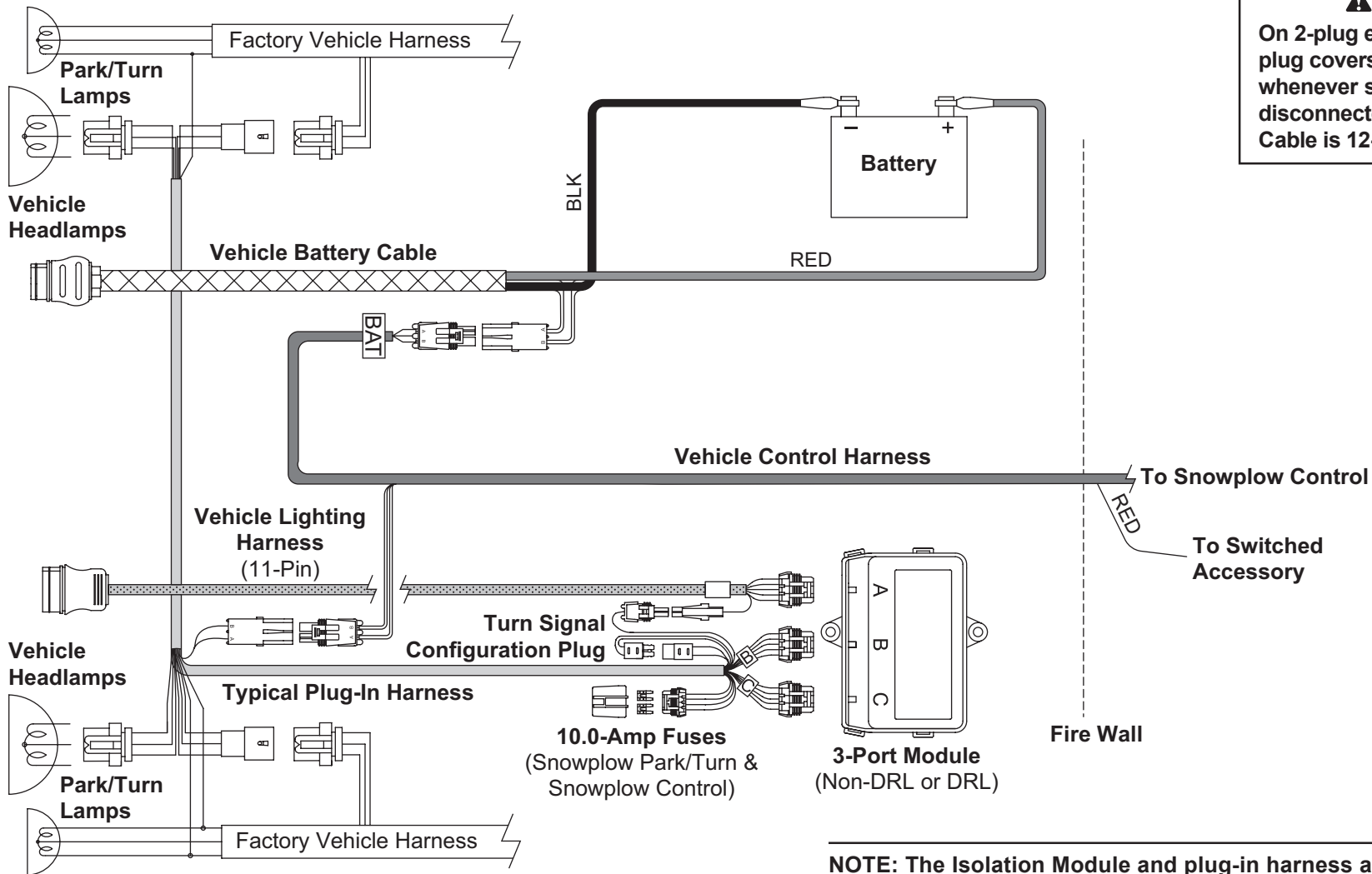

⚠ CAUTION
 On 2-plug electrical systems, plug covers shall be used whenever snowplow is disconnected. Vehicle Battery Cable is 12-volt unfused source.

NOTE: The Isolation Module and plug-in harness are shown on the driver side for illustration purposes only. Location may be different for the vehicle.

SYSTEM OVERVIEW – ELECTRICAL

ELECTRICAL ASSEMBLY

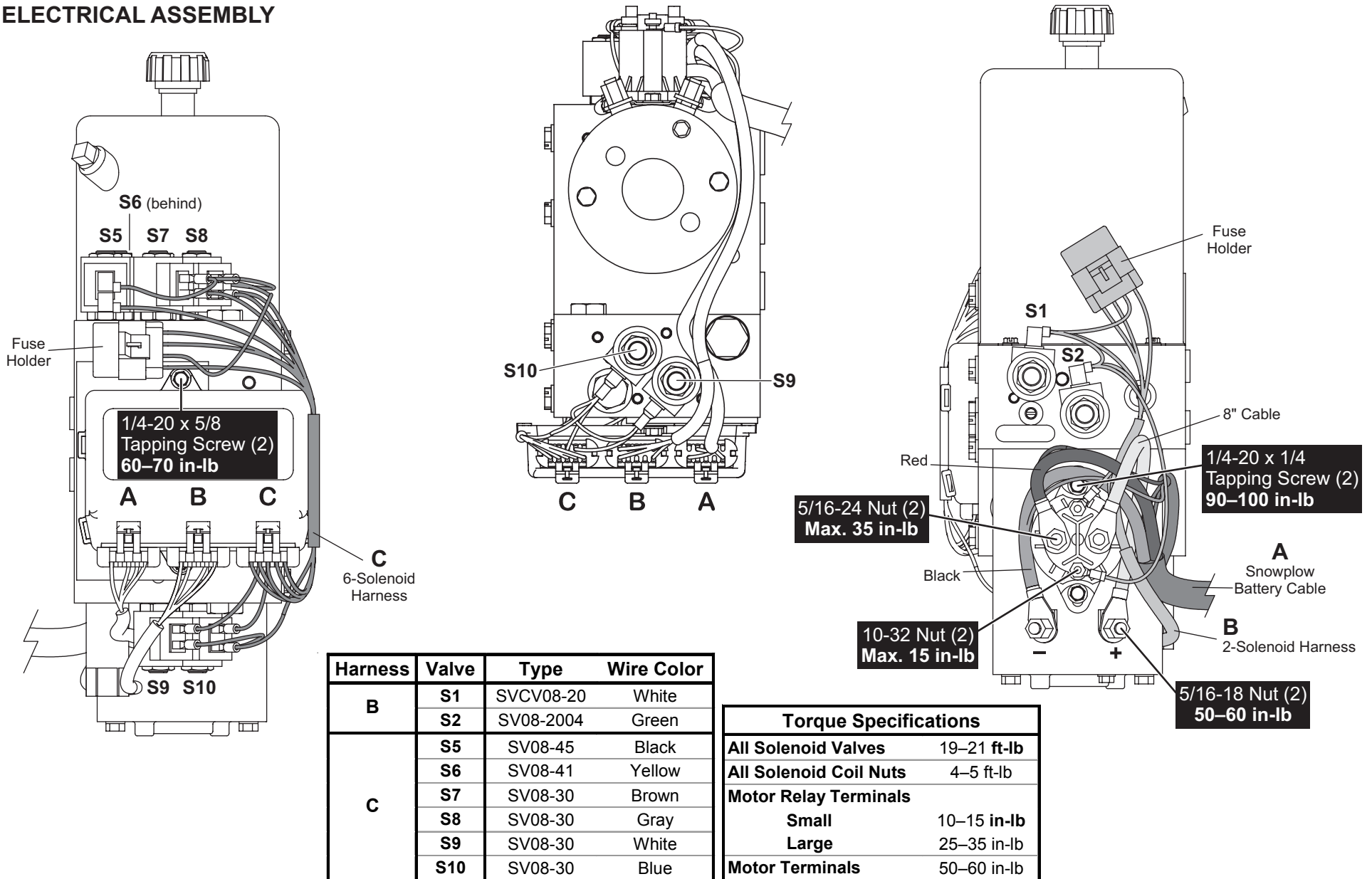

SYSTEM OVERVIEW – ELECTRICAL

COVER AND FINAL ASSEMBLY

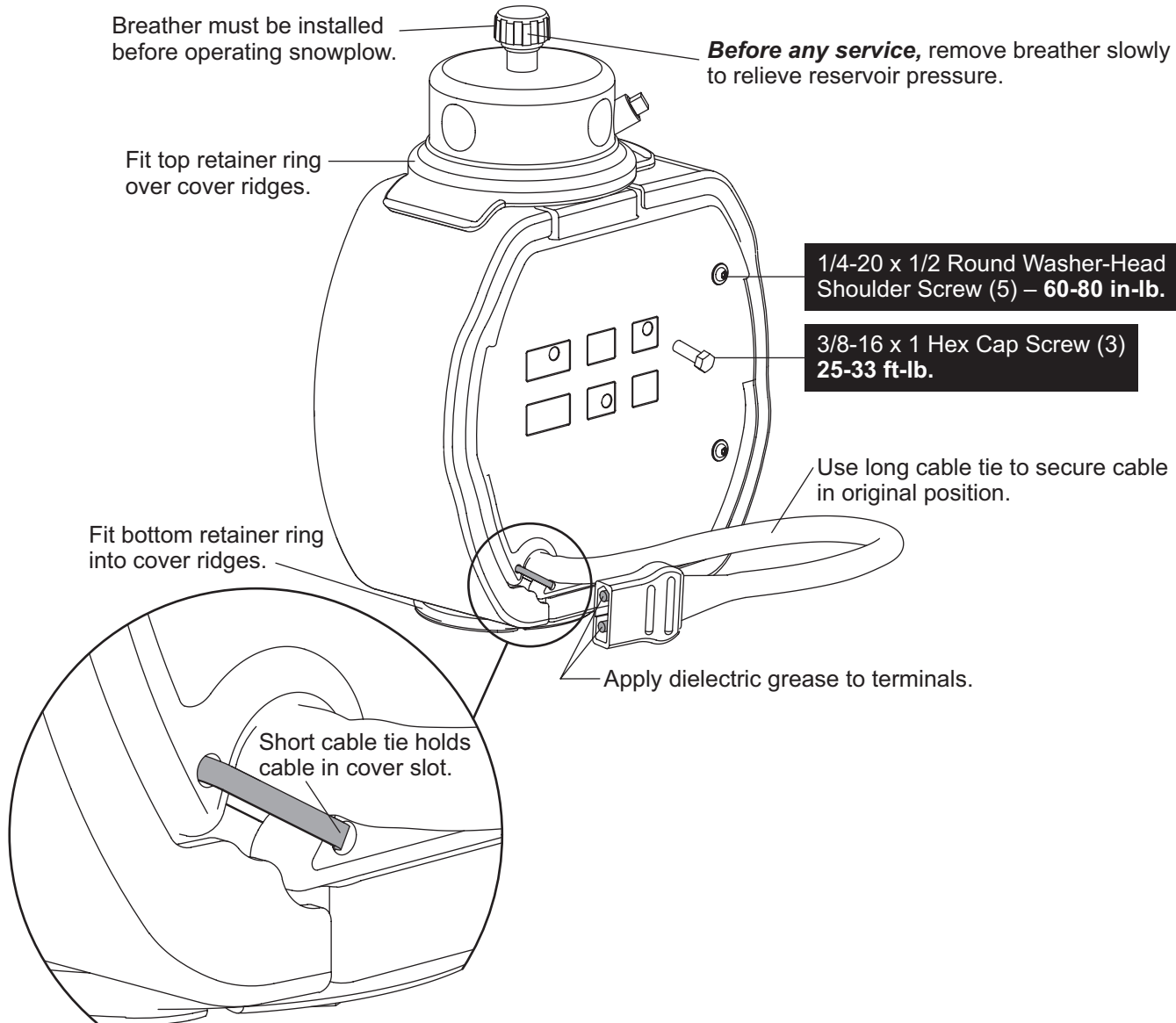

SYSTEM OVERVIEW – CONTROLS

GENERAL INFORMATION

⚠ WARNING

To prevent accidental movement of the blade, always push button to switch the control OFF whenever the snowplow is not in use. The control indicator light will turn off.

The XLS™ snowplow is operated by the Fish-Stik® 9-button hand-held control. The control allows you to go from an extra wide snowplow, to a scoop, to a standard straight-blade snowplow, all at the touch of a button.

The control has an ON/OFF switch with an indicator light to show when the control is powered up. Your

vehicle ignition (key) switch controls a fused circuit that powers your cab control directly from the battery.

The ON/OFF switch on the cab control allows you to turn OFF the control and prevent blade movement even when the ignition switch is ON.

The control ON/OFF switch serves as an emergency stop if required.

All controls are protected by a replaceable fuse located in the under hood snowplow electrical system. See Fuse Replacement in the Maintenance section of the Owner's Manual.

The control is able to sense a lack of communication with the electrical system. Should the indicator light start to flash, refer to the Control/Cable/Plow Module Test.

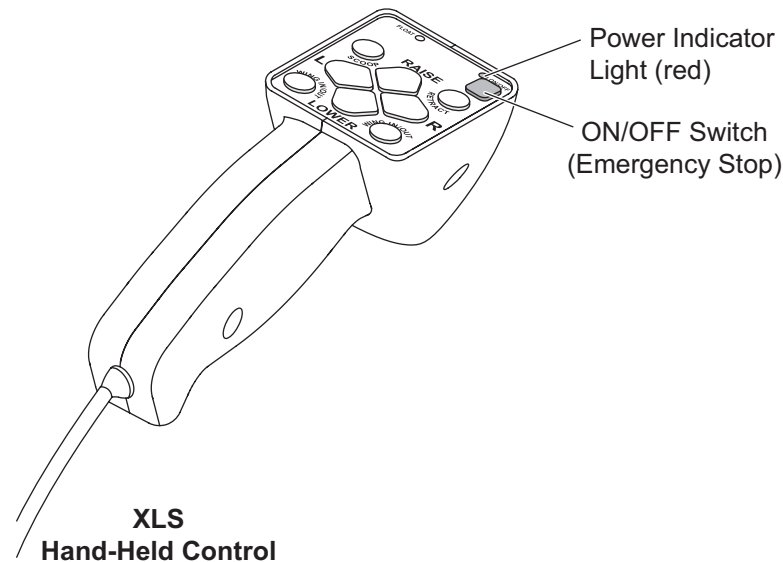

SYSTEM OVERVIEW – CONTROLS

XLS™ Fish-Stik® HAND-HELD CONTROL

⚠ WARNING

To prevent accidental movement of the blade, always push button to switch the control OFF whenever the snowplow is not in use. The control indicator light will turn off.

1. Turn the vehicle ignition switch to the ON or ACCESSORY position.
2. Press the ON/OFF switch on the control. The control indicator light glows red, indicating the control is ON. The indicator light glows red whenever the control and the vehicle ignition switch are both ON and the electrical connections to the snowplow are completed.

The ON/OFF switch operates as an emergency stop if required.

Function Time-Outs

All control functions, except LOWER/FLOAT, time out (stop) automatically after a period of time. This is to limit the amount of electrical energy required from the vehicle.

NOTE: If control function times out before desired blade movement is complete, refer to the Troubleshooting section at the end of this guide.

Automatic Shutdown

The control will automatically turn OFF after being idle for 20 minutes.

Smooth Stop

The control automatically allows the blade to coast to a stop when the button is released. This results in smoother operation, reduces the shock to the hydraulic system and increases hose and valve life.

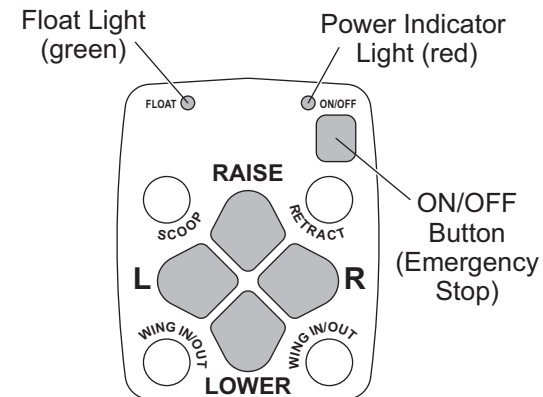

SYSTEM OVERVIEW – CONTROLS

Control Functions

Raise, Lower, Float, Angle

The four diamond-shaped buttons in the center of the control face, when pressed, will result in the blade movements described in the table:

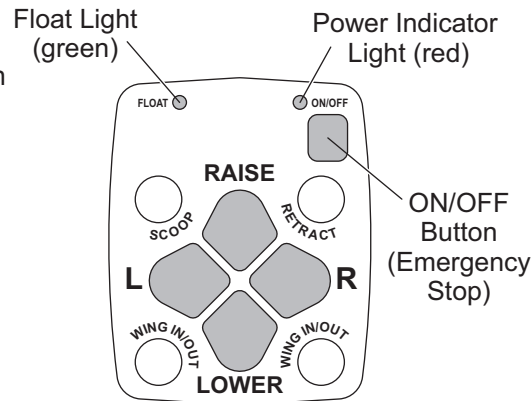

Function	Description of Operation
RAISE	Press this button to raise the snowplow and cancel the FLOAT mode. Function times out after 3.5 seconds.
LOWER	Press this button to lower the snowplow. Release the button to stop blade at desired height.
FLOAT	Press the LOWER button and hold 3/4 second to activate this mode. The FLOAT indicator light in the upper left corner of the control face will illuminate. The blade will lower to the ground surface and follow the contour of the surface as it dips or raises. Function does not time out, but control will shut down after 20 minutes of nonuse. Press RAISE button momentarily to cancel FLOAT. Angling left or right will not interrupt (stop) the FLOAT function.
L – Angle Left	Press the L button to move the blade to the angle left position to cast snow to the driver's left side. Function times out after 3.25 seconds.
R – Angle Right	Press the R button to move the blade to the angle right position to cast snow to the driver's right side. Function times out after 3.25 seconds.

Scoop/Retract Blade Position

The two round buttons located to the left and right of the RAISE button move both wings at the same time into the blade positions described in the following table:

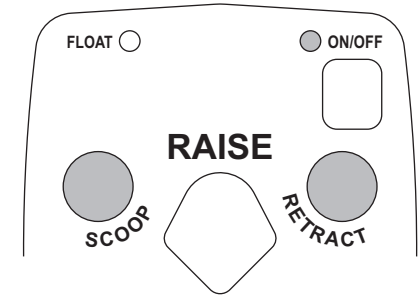

Function	Description of Operation
SCOOP	Press this button to extend both wings forward into the scoop position. Function times out after 5.5 seconds.
RETRACT	Press this button to draw both wings into the retract position. Function times out after 4.5 seconds.

Wing Positions

The two round buttons located to the left and right of the LOWER button move either wing independently of the other as described in the following table:

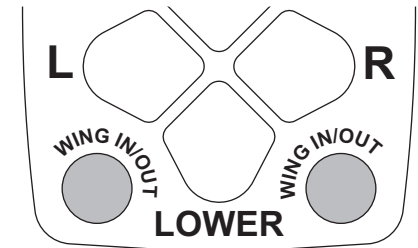

Function	Description of Operation
L WING IN/OUT	Press the round WING IN/OUT button on the left side of the control to move the left wing. The first time the button is pressed after the control is turned ON or another function is used, the wing will extend. Repeated use of the same button, without using another function, results in movement in the opposite direction from the previous movement. Function times out after 3.25 (IN) or 3.75 (OUT) seconds.
R WING IN/OUT	Press the round WING IN/OUT button on the right side of the control to move the right wing. The first time the button is pressed after the control is turned ON or another function is used, the wing will extend. Repeated use of the same button, without using another function, results in movement in the opposite direction from the previous movement. Function times out after 3.25 (IN) or 3.75 (OUT) seconds.

Excerpts taken from Minute Mount® 2 Owner's Manual (Lit. No. 44224, Rev. 05).

THEORY OF OPERATION

SNOWPLOW HYDRAULICS

The XLS™ snowplow hydraulic system performs ten blade movements.

All movements require the vehicle ignition (key) switch to be in the run or accessory position and the power to be activated on the snowplow cab control.

Nine of the ten hydraulic movements require energizing the electric motor and appropriate solenoid cartridge valves. The tenth function, LOWER, does not energize the motor but requires activating a cartridge valve.

Power from the vehicle battery is supplied to the solenoid coils and the motor relay via the Plow Module. The solenoid cartridge valves operate in various combinations, directed by the cab control, to send hydraulic fluid to the snowplow lift, angle and wing rams or back to the reservoir. Power is supplied to the Plow Module via the Isolation Module.

4-PORT MODULE ELECTRICAL

Snowplow Headlamps

The Isolation Module acts as an electrical hub, automatically directing vehicle power to the appropriate vehicle or snowplow lighting devices, while also supplying battery power to the snowplow control.

The vehicle high and low beams enter and exit the Isolation Module through positions 3 (left-side lighting) and position 4 (right-side lighting). Park, turn and DRL signals also enter through positions 3 and 4. The output of the vehicle dimmer switch is directed to the Isolation Module via the long and short plug-in harnesses.

All snowplow lighting exits the Isolation Module through position 2.

When the snowplow is not attached to the vehicle, the signal passes through the normally closed relay contacts to the vehicle headlamps. During this time, the Isolation Module is inactive, placing no current draw on the vehicle's electrical system.

With the snowplow attached, the Isolation Module is still inactive until either of the two following conditions are met: The vehicle parking lights are turned ON or the vehicle ignition switch is turned ON.

Turning ON the vehicle parking lights activates a series of relays, automatically transferring the vehicle high and low beams to the snowplow while supplying battery power directly to the snowplow parking lights.

Turning ON the vehicle ignition switch energizes a snowplow control relay, supplying vehicle battery power directly to the control via the vehicle control harness. The vehicle ignition switch also supplies power to the vehicle turn signals. Activating the vehicle turn signals energizes turn signal relays, which supply vehicle battery power directly to the snowplow turn signals.

Snowplow Daytime Running Lights

Because Daytime Running Lamps (DRLs) are controlled differently on some vehicles, two Isolation Modules have been developed.

The standard Isolation Module transfers the DRL output from the vehicle headlamps to the snowplow lights when the vehicle ignition switch is turned ON and the snowplow is attached.

The second Isolation Module, designed for vehicles with dedicated DRL bulbs, senses the vehicle in the DRL mode and a series of relays energize, placing the snowplow low beams in series. This Isolation Module does not turn OFF the vehicle's dedicated DRLs.

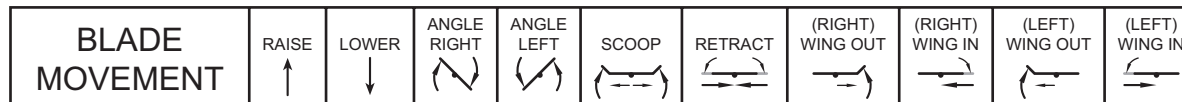

THEORY OF OPERATION

3-PORT MODULE ELECTRICAL

Overview

The Isolation Module acts as an electrical hub, automatically directing vehicle power to the appropriate vehicle or snowplow lighting devices, while also supplying battery power to the snowplow control.

The vehicle high and low beams enter and exit the Isolation Module through positions B (left side lighting) and position C (right side lighting). Park, turn, and DRL signals also enter through positions B and C.

The output of the vehicle high beam/low beam select switch is directed to the Isolation Module via the plug-in harness. When the snowplow is not attached to the vehicle, the signal passes through the normally closed relay contacts to the vehicle headlamps. During this time, the Isolation Module is inactive, placing no current draw on the vehicle's electrical system.

With the snowplow attached, the Isolation Module is still inactive until either of the two following conditions are met: the vehicle parking lights are turned ON or the vehicle ignition switch is turned ON.

Turning ON the vehicle parking lights activates a series of relays, automatically transferring the vehicle high and low beams to the snowplow while supplying battery power directly to the snowplow parking lights. All snowplow lighting exits the Isolation Module through position A.

Turning ON the vehicle ignition switch energizes a snowplow control relay, supplying vehicle battery power directly to the control via the vehicle control harness and plug-in harness. The vehicle ignition switch also supplies power to the vehicle turn signals. Activating the vehicle turn signals energizes turn signal circuit, which supply vehicle battery power directly to the snowplow turn signals.

NOTE: References to "Left" and "Right" are correct for modules located on the driver's side of the vehicle. The reversible turn signal plug must be reversed for passenger-side installations.

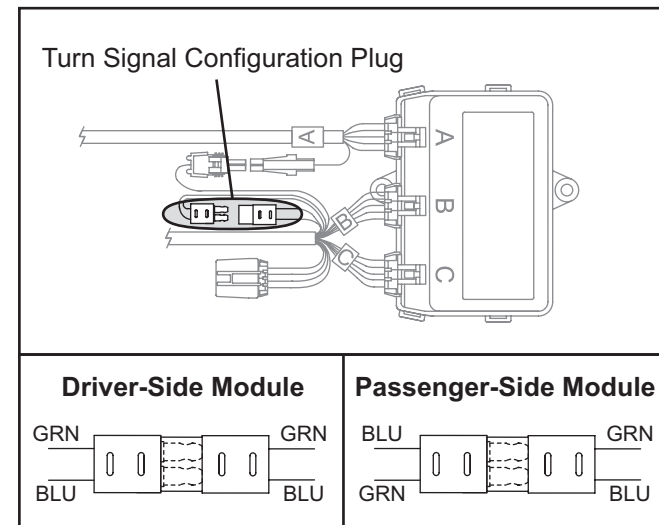

THEORY OF OPERATION

3-PORT MODULE ELECTRICAL

White Label Non-DRL Module (PN 29060)

Snowplow not attached to vehicle:

System is inactive. Vehicle lighting system functions normally. Reason: No ground to module.

Snowplow attached to vehicle:

System is inactive until either the switched accessory wire or the vehicle parking lights are activated. Vehicle and snowplow lighting systems function as outlined in the Theory of Operation Overview. Reason: ground path is established from battery common to Pin C on Port A of the 3-port module via the following harnesses: vehicle battery cable, vehicle control harness, adapter, plug-in harness, vehicle lighting harness and snowplow lighting harness.

- Activating a **switched accessory** wire (a key-controlled power source) applies battery voltage to the VACC input of the module, which energizes the coil of the control power relay (part of the 3-port module). Energizing the coil of the control power relay causes the relay contacts to shift from the "N.O." (normally opened) position to the "N.C." (normally closed) position, which supplies battery voltage to the snowplow control via the plug-in harness and the vehicle control harness. The switched accessory wire only controls battery voltage to the snowplow control.
- Activating the vehicle **park light** circuit applies battery voltage to the module park circuit input. The voltage is applied to a solid state power device, which causes the device to turn ON and apply battery voltage to the snowplow park lamp filaments via the vehicle and snowplow lighting harnesses. Voltage is also applied to the module's high and low beam relay coils, which causes the relay contacts to shift from the "vehicle" to the "snowplow" position.
- With the four headlamp relays shifted to the "snowplow" position, the **vehicle high and low beams** are now directed to the snowplow headlamps via the vehicle and snowplow lighting harnesses. Toggling the dimmer switch between high and low beam will toggle the snowplow high and low beams.
- Activating the **turn signal** applies battery voltage to the module turn signal circuit input. The voltage is applied to a solid state power device, which causes the device to turn ON and apply battery voltage to the snowplow turn signal lamp filaments via the vehicle and snowplow lighting harnesses.
- On vehicles equipped with **DRLs**—either integrated into the vehicle headlamps or separated into dedicated DRL lamps—this module *will not* turn OFF the vehicle DRLs or transfer them to the snowplow. DRLs will remain on the vehicle and operate as the vehicle manufacturer intended.

THEORY OF OPERATION

3-PORT MODULE ELECTRICAL

Green Label DRL Module (PN 29070)

Snowplow not attached to vehicle:

System is inactive. Vehicle lighting system functions normally. Reason: No ground to module.

Snowplow attached to vehicle:

System is inactive until either the switched accessory wire or the vehicle parking lights are activated. Vehicle and snowplow lighting systems function as outlined in the Theory of Operation Overview. Reason: ground path is established from battery common to Pin C on Port A of the 3-port module via the following harnesses: vehicle battery cable, vehicle control harness, adapter, plug-in harness, vehicle lighting harness and snowplow lighting harness.

- Activating a **switched accessory** wire (a key-controlled power source) applies battery voltage to the VACC input of the module. A control circuit senses the voltage and energizes the coil of the control power relay (part of the 3-port module). Energizing the coil of the control power relay causes the relay contacts to shift from the "N.O." (normally opened) position to the "N.C." (normally closed) position, which supplies battery voltage to the snowplow control via the plug-in harness and the vehicle control harness. The switched accessory wire only controls battery voltage to the snowplow control.
- Activating the vehicle **park light** circuit applies voltage to the module park circuit input. A control circuit senses the voltage and turns ON a solid state power device, which applies battery voltage to the snowplow park lamp filaments via the vehicle and snowplow lighting harnesses.
- With the park light circuit energized, the control circuit monitors the **vehicle high and low beam** inputs. When battery voltage is sensed, the appropriate solid state power devices are turned ON, supplying battery voltage to the snowplow headlamps via the vehicle and snowplow lighting harnesses. Toggling the dimmer switch between high and low beam will toggle the snowplow high and low beams.
- Activating the **turn signal** applies voltage to the module turn signal circuit input. A control circuit senses the voltage and turns ON a solid state power device, which applies battery voltage to the snowplow turn signal lamp filaments via the vehicle and snowplow lighting harnesses.
- On vehicles equipped with **DRLs**—either integrated into the vehicle headlamps or separated into dedicated DRL lamps—this module *will not* turn OFF the vehicle DRLs. The control circuit monitors the voltage level supplied by the vehicle to the vehicle high and low beams as well as the dedicated DRL inputs. When a lower voltage is sensed on either the high or low beam inputs or battery voltage is sensed on the dedicated DRL input, the control circuit turns ON the snowplow turn signal filaments to operate as DRLs via the vehicle and snowplow lighting harnesses.

THEORY OF OPERATION

3-PORT MODULE ELECTRICAL

Blue Label DRL Module (PN 29760-1)

Snowplow not attached to vehicle:

System is inactive. Vehicle lighting system functions normally. Reason: No ground to module.

Snowplow attached to vehicle:

System is inactive until either the switched accessory wire or the vehicle parking lights are activated. Vehicle and snowplow lighting systems function as outlined in the Theory of Operation Overview. Reason: ground path is established from battery common to Pin C on Port A of the 3-port module via the following harnesses: vehicle battery cable, vehicle control harness, adapter, plug-in harness, vehicle lighting harness and snowplow lighting harness.















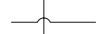





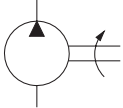

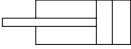





- Activating a **switched accessory** wire (a key-controlled power source) applies battery voltage to the VACC input of the module, which energizes the coil of the control power relay (part of the 3-port module). Energizing the coil of the control power relay causes the relay contacts to shift from the "N.O." (normally opened) position to the "N.C." (normally closed) position, which supplies battery voltage to the snowplow control via the plug-in harness and the vehicle control harness.
- Activating the vehicle **park light** circuit applies battery voltage to the module park circuit input. The voltage is applied to a solid state power device, which causes the device to turn ON and apply battery voltage to the snowplow park lamp filaments via the vehicle and snowplow lighting harnesses. Voltage is also applied to the module's high and low beam relay coils, which causes the relay contacts to shift from the "vehicle" to the "snowplow" position.
- With the four headlamp relays shifted to the "snowplow" position, the **vehicle high and low beams** are now directed to the snowplow headlamps via the vehicle and snowplow lighting harnesses. Toggling the dimmer switch between high and low beam will toggle the snowplow high and low beams.
- Activating the **turn signal** applies battery voltage to the module turn signal circuit input. The voltage is applied to a solid state power device, which causes the device to turn ON and apply battery voltage to the snowplow turn signal lamp filaments via the vehicle and snowplow lighting harnesses.
- On vehicles equipped with **DRLs** integrated into the vehicle headlamps, activating a **switched accessory** wire (a key-controlled power source) applies battery voltage to the module's **high and low beam** relay coils, which causes the relay contacts to shift from the "vehicle" to the "snowplow" position. This module *will* transfer the vehicle DRLs to the snowplow.

ELECTRICAL & HYDRAULIC SCHEMATICS

The following section contains hydraulic and electrical schematics to help explain how the hydraulic unit performs the different functions. A schematic is an abstract drawing showing the *purpose* of each of the components in the system. Each component is represented by a graphical symbol. The hydraulic and electrical legends describe each of the symbols used in the schematics for this guide.

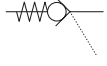
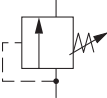
The first three schematics show a general overview of the complete hydraulic and electrical systems. Other schematics highlight the flow of hydraulic fluid and electrical current for each function the hydraulic unit performs as well as the flow of electrical current for the snowplow and vehicle lights.

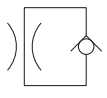
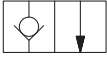
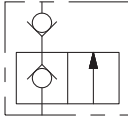
- Bold lines represent the circuit being activated only.
- Shaded components are either activated or shifted from their normal position.

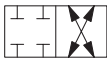
ELECTRICAL LEGEND		HYDRAULIC LEGEND	
	CROSSING WIRE		LINE, WORKING (MAIN)
	WIRE SPLICE		LINES JOINING
	IN-LINE CONNECTOR		LINES CROSSING
	FUSE		FLOW, DIRECTION OF HYDRAULIC FLUID
	SOLENOID COIL		LINE, TO RESERVOIR BELOW FLUID LEVEL
	CIRCUIT GROUND		HYDRAULIC PUMP FIXED DISPLACEMENT
	MOTOR RELAY		RAM
	BATTERY		ELECTRIC MOTOR
	MOTOR		FILTER, STRAINER, DIFFUSER
	HEADLAMP		COMPONENT ENCLOSURE
	PARK/TURN LAMP		SPRING
	PRINTED CIRCUIT BOARD		SOLENOID, SINGLE WINDING
	COMPONENT ENCLOSURE		CHECK VALVE
			PILOT-OPERATED CHECK VALVE
			VALVE, ADJUSTABLE PRESSURE RELIEF
			VALVE, FLOW CONTROL, ADJUSTABLE-NON-COMPENSATED
			ORIFICE PLATE
			VALVE, TWO POSITION, TWO CONNECTION (TWO WAY)
			VALVE, TWO POSITION, TWO CONNECTION (TWO WAY) WITH INTEGRAL CHECK VALVE
			VALVE, TWO POSITION, THREE CONNECTION (THREE WAY)
			VALVE, TWO POSITION, FOUR CONNECTION (FOUR WAY)

ELECTRICAL SCHEMATIC – 4-PORT MODULE

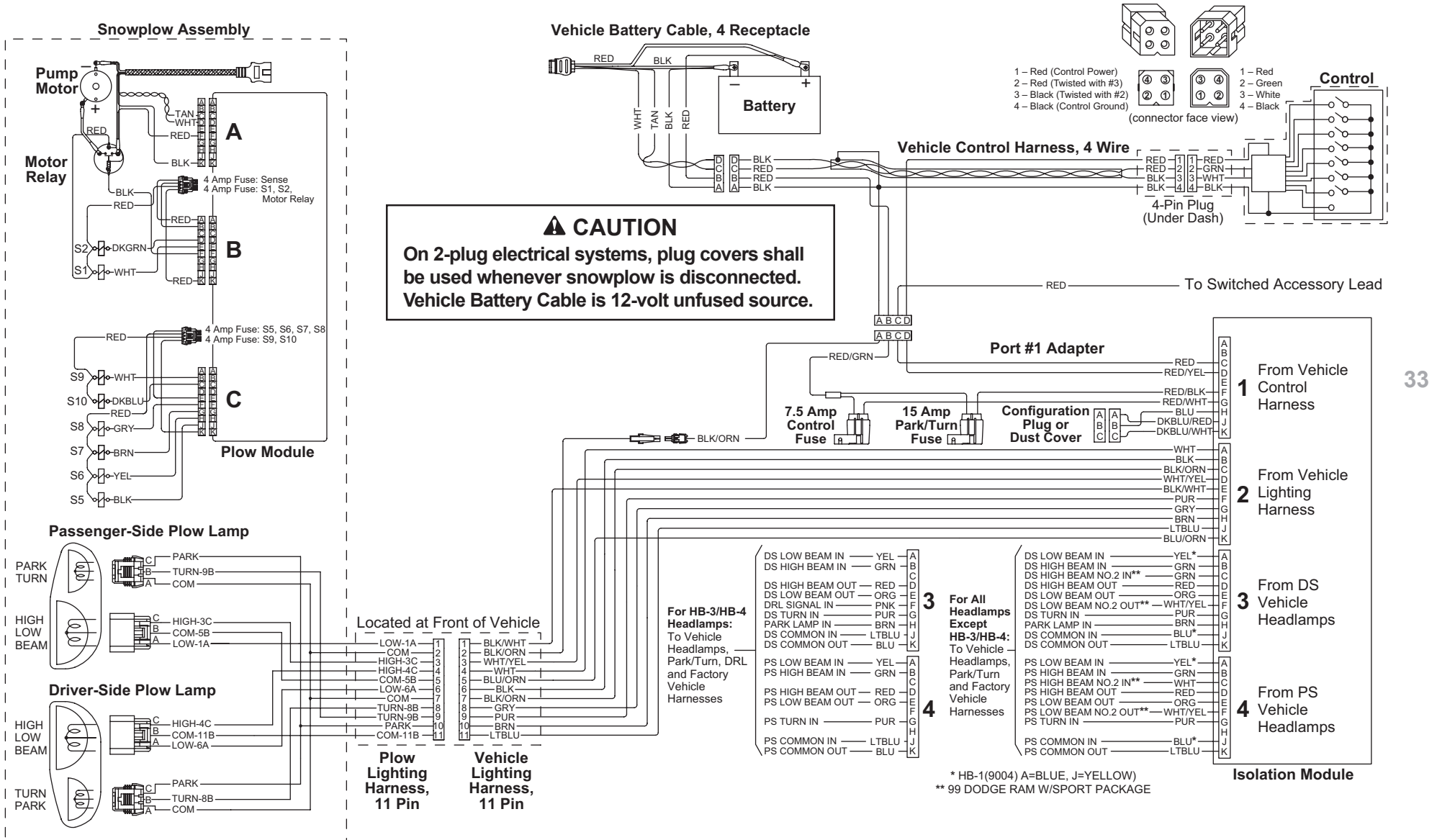

ELECTRICAL SCHEMATIC – 3-PORT MODULE

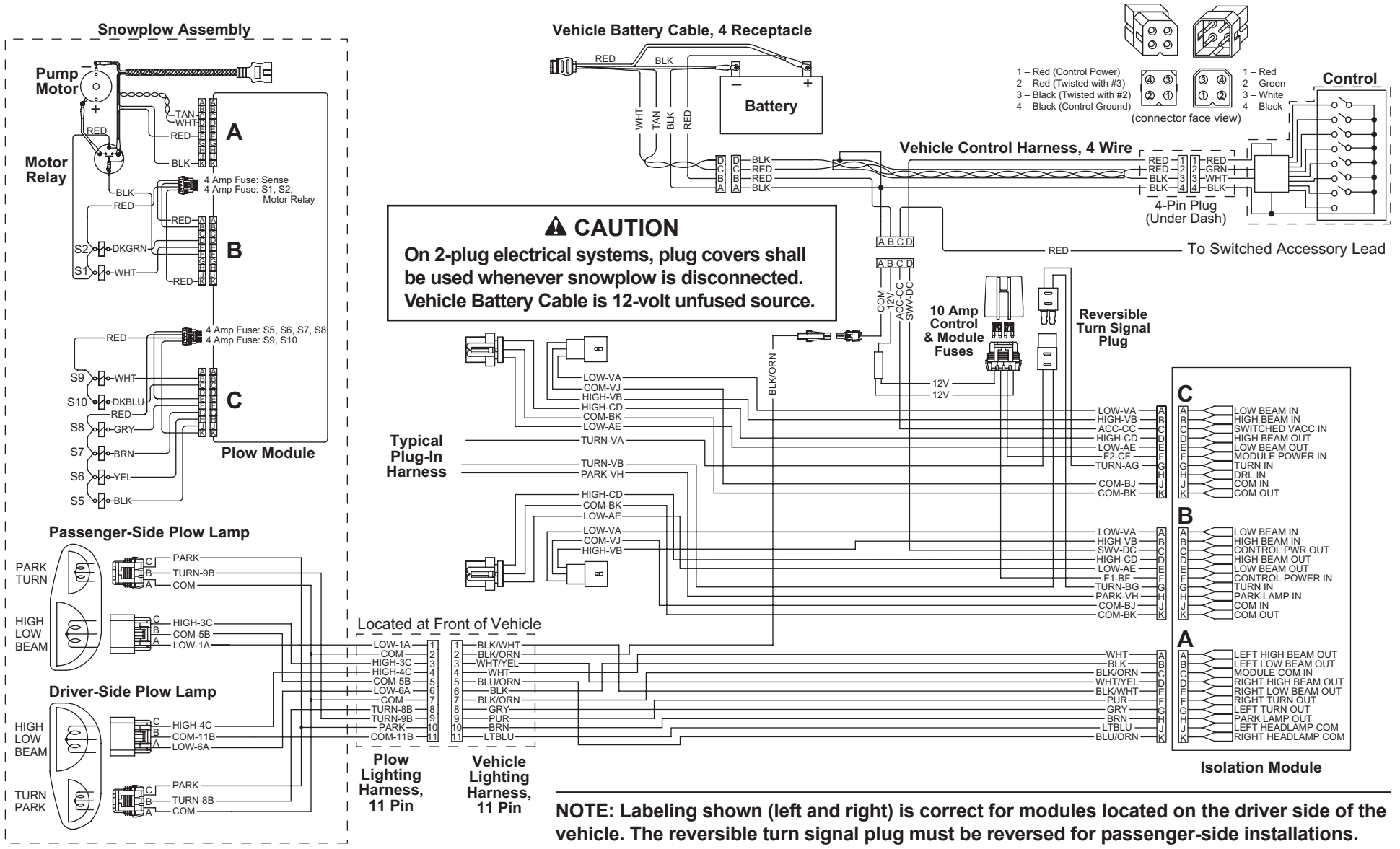

HYDRAULIC SCHEMATIC

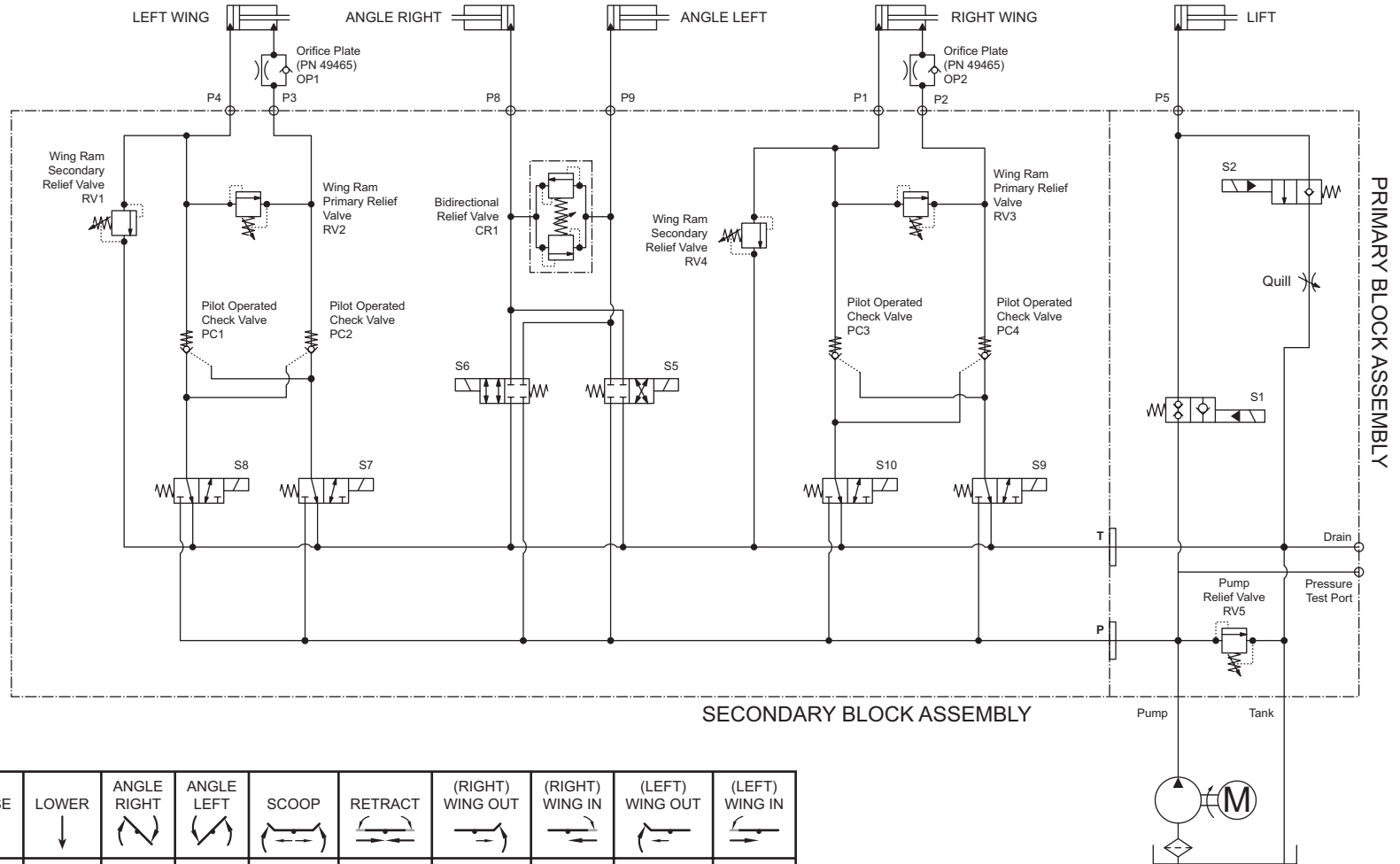

35

BLADE MOVEMENT		RAISE ↑	LOWER ↓	ANGLE RIGHT 	ANGLE LEFT 	SCOOP 	RETRACT 	(RIGHT) WING OUT 	(RIGHT) WING IN 	(LEFT) WING OUT 	(LEFT) WING IN
MOTOR	M	ON		ON	ON	ON	ON	ON	ON	ON	ON
SV08-20	S1	ON									
SV08-2004	S2		ON								
SV08-45	S5			ON							
SV08-41	S6				ON						
SV08-30	S7					ON					ON
SV08-30	S8					ON				ON	
SV08-30	S9						ON	ON			
SV08-30	S10					ON	ON				

Relief Valve Settings	
Pump (RV5)	2250 psi
Wing Ram, Secondary (RV1, RV4)	1700 psi
Wing Ram, Primary (RV2, RV3)	1500 psi

RAISE – ELECTRICAL

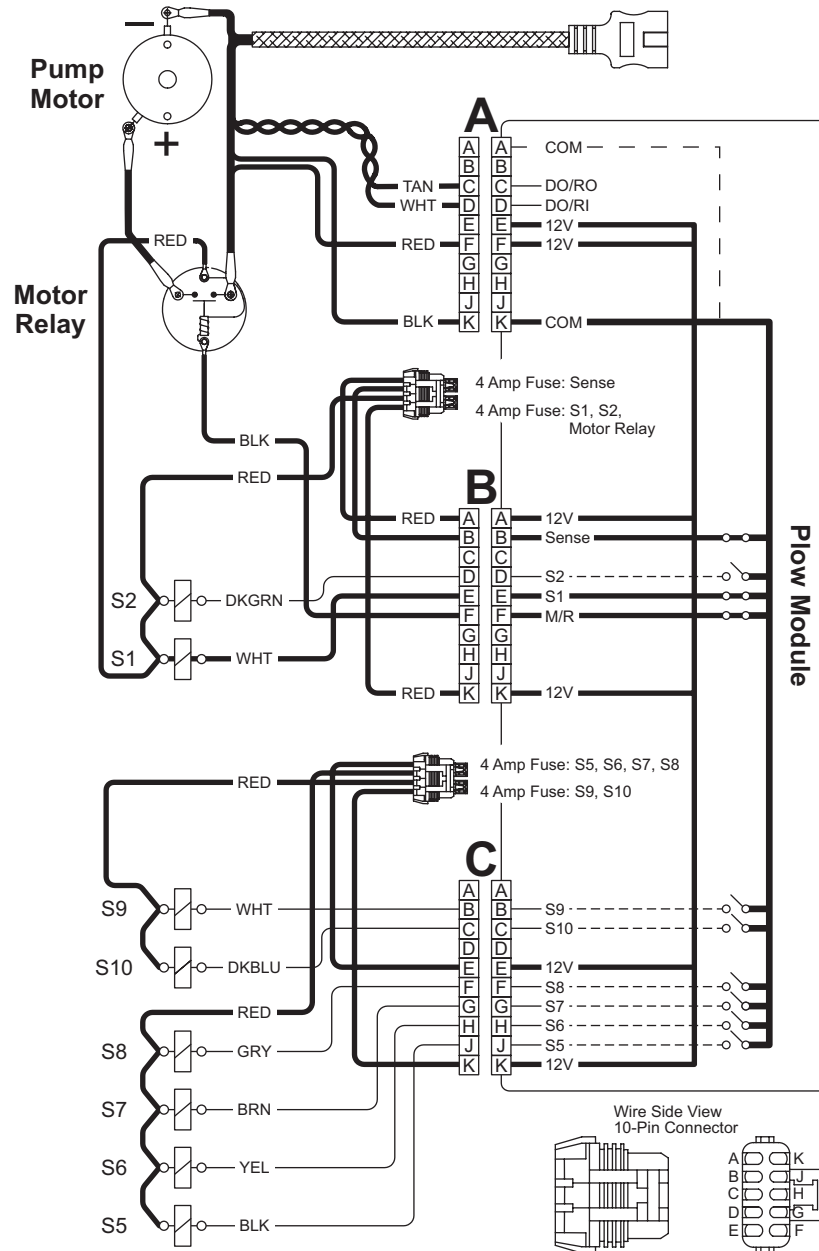

System Response

1. By activating the RAISE function on the cab control, the control sends a signal to the Plow Module to complete the **ground path** for the electrical circuit, activating the motor relay and solenoid cartridge valve S1.
2. Hydraulic fluid from the pump flows through S1 and fills the base end of the lift ram, extending the rod.

NOTE: Battery voltage is supplied to the Plow Module, the motor relay and the 8 solenoid coils when the snowplow is connected to the vehicle.

RAISE – HYDRAULIC

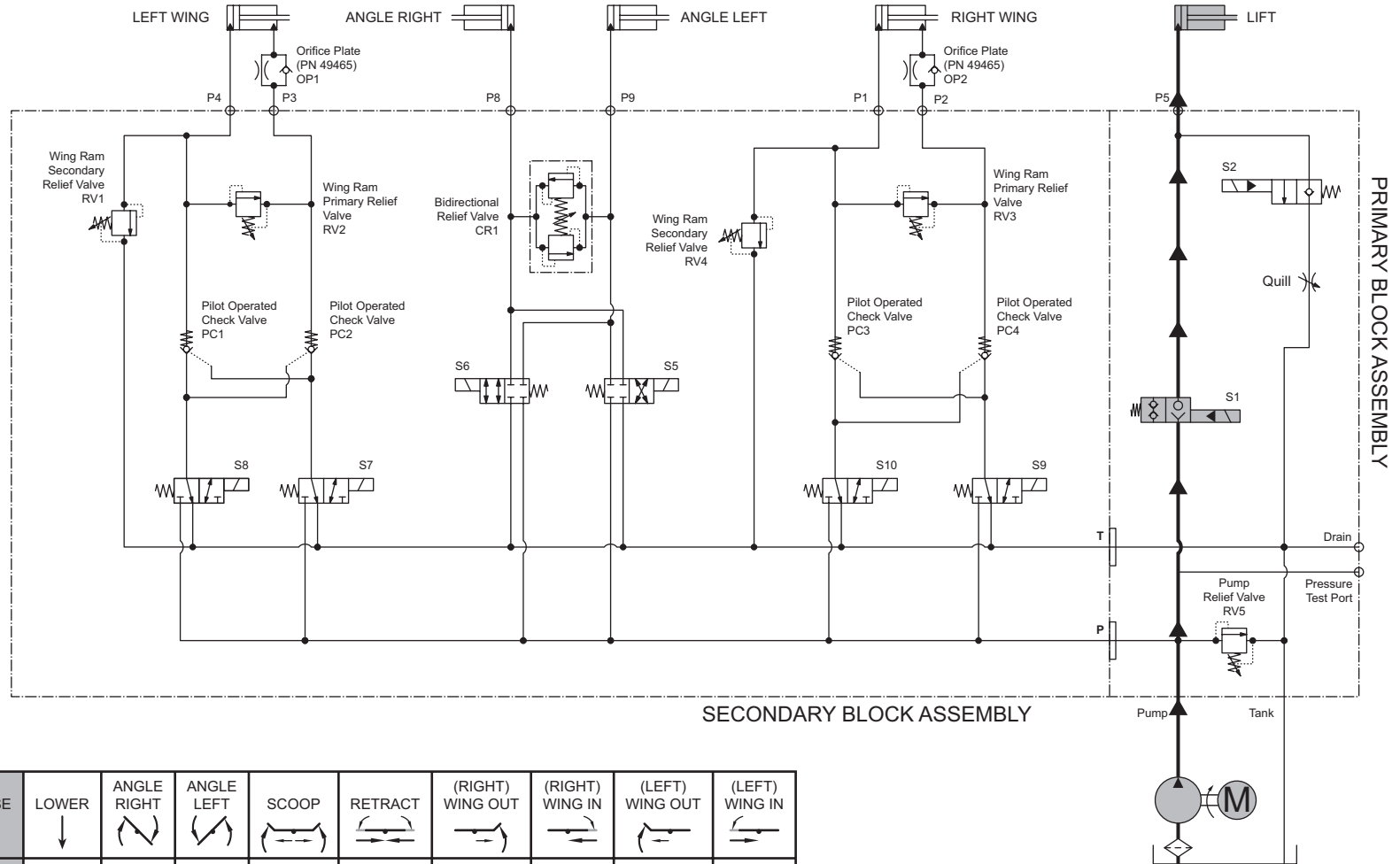

BLADE MOVEMENT		RAISE ↑	LOWER ↓	ANGLE RIGHT 	ANGLE LEFT 	SCOOP 	RETRACT 	(RIGHT) WING OUT 	(RIGHT) WING IN 	(LEFT) WING OUT 	(LEFT) WING IN
MOTOR	M	ON		ON	ON	ON	ON	ON	ON	ON	ON
SV08-20	S1	ON									
SV08-2004	S2		ON								
SV08-45	S5			ON							
SV08-41	S6				ON						
SV08-30	S7					ON					ON
SV08-30	S8					ON				ON	
SV08-30	S9						ON	ON			
SV08-30	S10					ON	ON				

Relief Valve Settings	
Pump (RV5)	2250 psi
Wing Ram, Secondary (RV1, RV4)	1700 psi
Wing Ram, Primary (RV2, RV3)	1500 psi

LOWER – ELECTRICAL

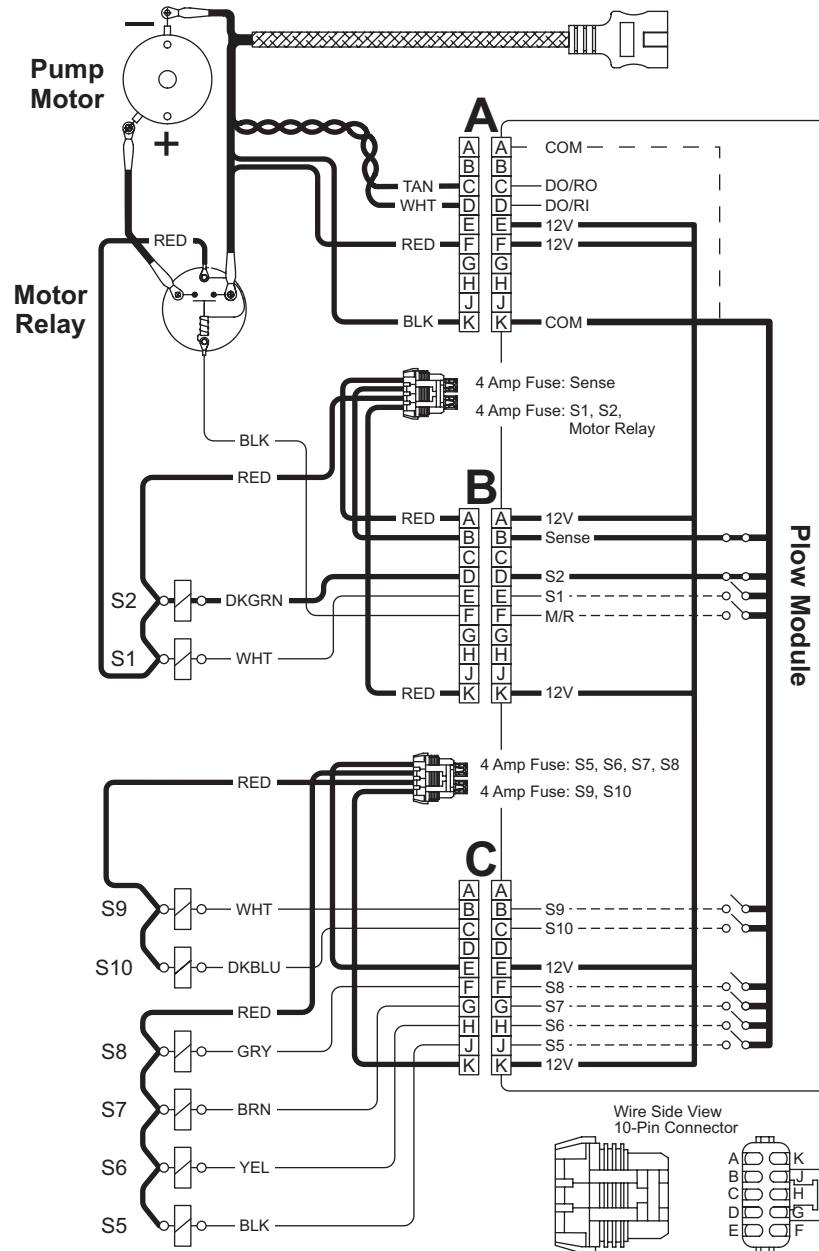

System Response

1. By activating the LOWER function on the cab control, the control sends a signal to the Plow Module to complete the **ground path** for the electrical circuit, activating solenoid cartridge valve S2.
2. With the weight of the snowplow on the rod end of the lift ram and S2 cartridge valve shifted, the lift ram retracts. Hydraulic fluid is pushed out of the base end, through S2 and back to the reservoir.

NOTE: Battery voltage is supplied to the Plow Module, the motor relay and the 8 solenoid coils when the snowplow is connected to the vehicle.

LOWER – HYDRAULIC

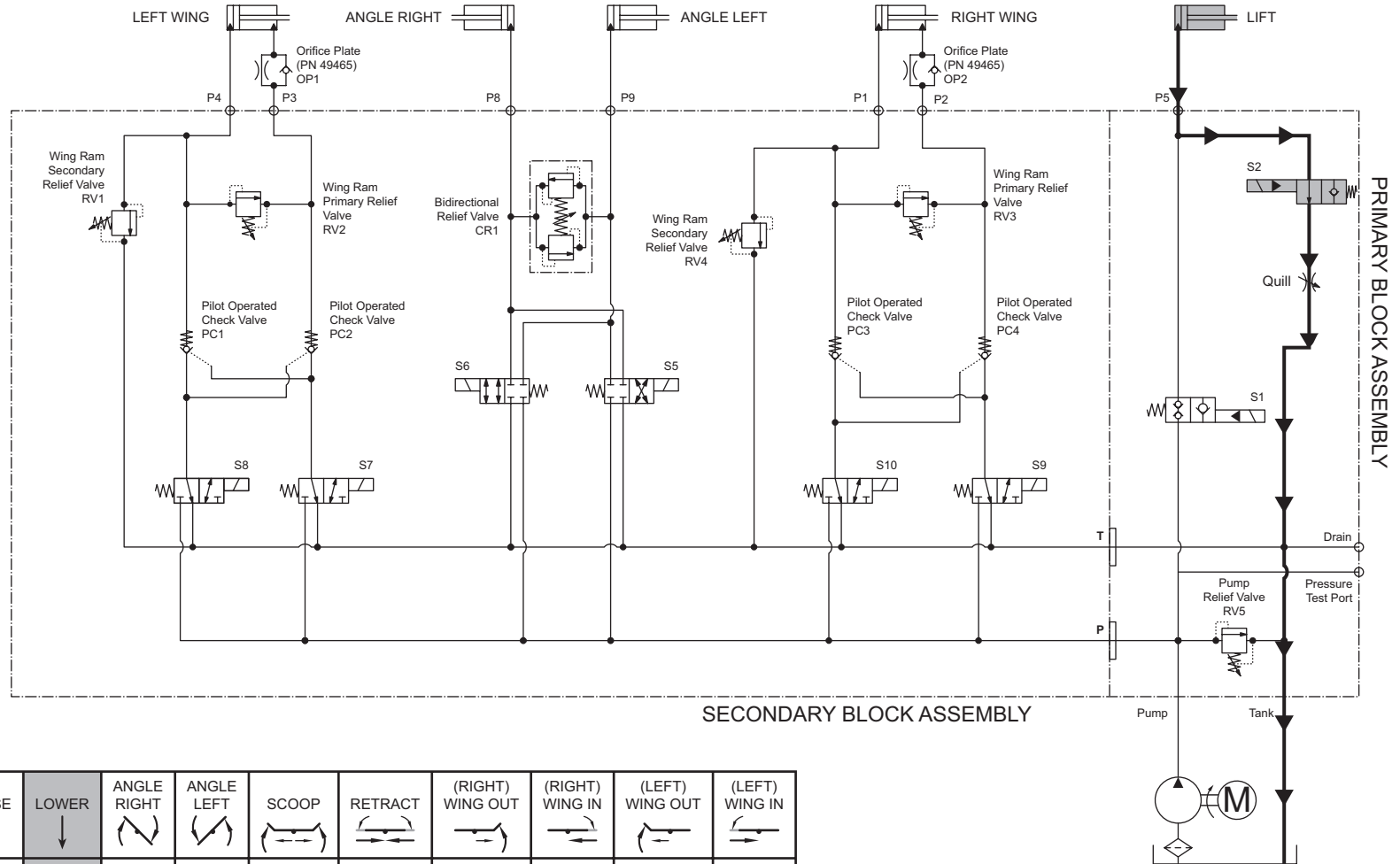

BLADE MOVEMENT		RAISE ↑	LOWER ↓	ANGLE RIGHT 	ANGLE LEFT 	SCOOP 	RETRACT 	(RIGHT) WING OUT 	(RIGHT) WING IN 	(LEFT) WING OUT 	(LEFT) WING IN
MOTOR	M	ON		ON	ON	ON	ON	ON	ON	ON	ON
SV08-20	S1	ON									
SV08-2004	S2		ON								
SV08-45	S5			ON							
SV08-41	S6				ON						
SV08-30	S7					ON					ON
SV08-30	S8					ON				ON	
SV08-30	S9						ON	ON			
SV08-30	S10					ON	ON				

Relief Valve Settings	
Pump (RV5)	2250 psi
Wing Ram, Secondary (RV1, RV4)	1700 psi
Wing Ram, Primary (RV2, RV3)	1500 psi

ANGLE RIGHT – ELECTRICAL

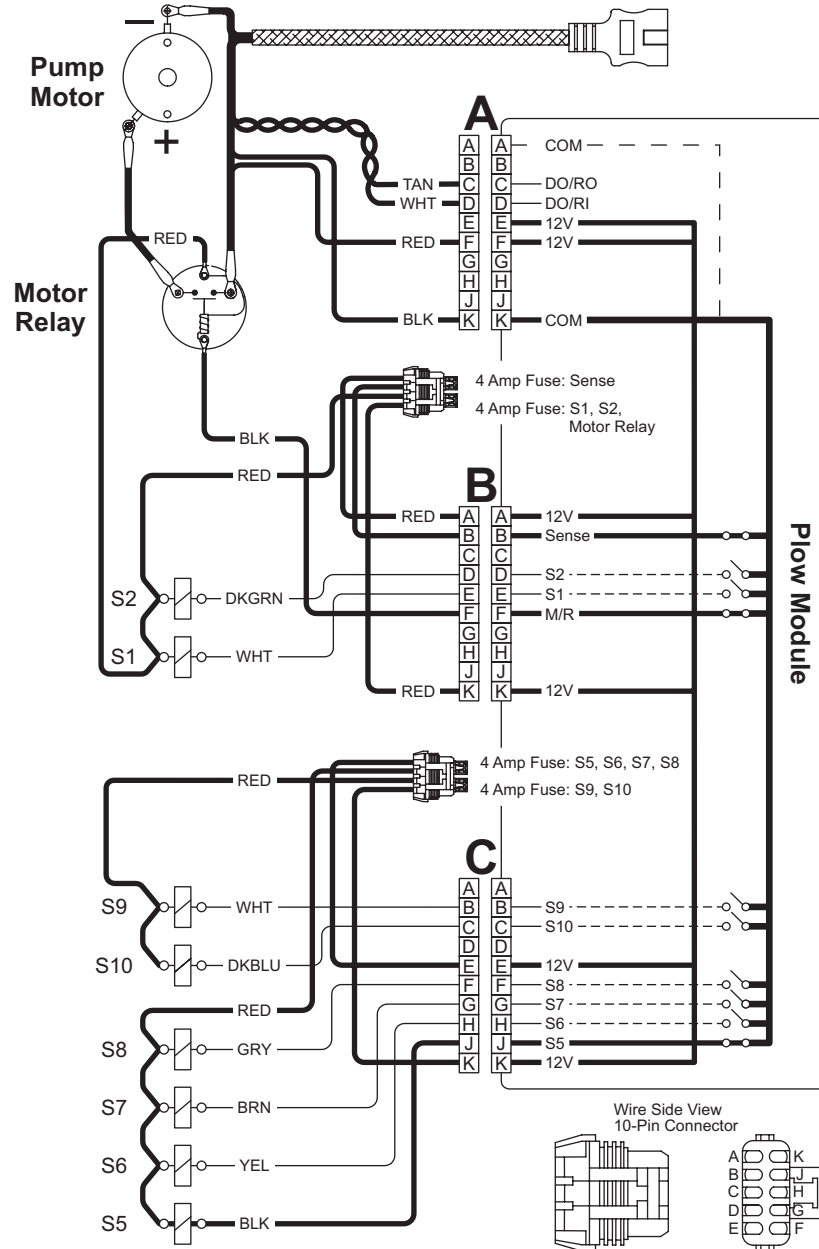

System Response

1. By activating the angle right (R on the control face) function on the cab control, the control sends a signal to the Plow Module to complete the **ground path** for the electrical circuit, activating the motor relay and solenoid cartridge valve S5.
2. Hydraulic fluid from the pump flows through activated S5 and into the base end of the DS cylinder, causing it to extend.
3. The retracting PS ram pushes the hydraulic fluid out of its base end, through activated S5 and back to the reservoir.

NOTE: Battery voltage is supplied to the Plow Module, the motor relay and the 8 solenoid coils when the snowplow is connected to the vehicle.

ANGLE RIGHT – HYDRAULIC

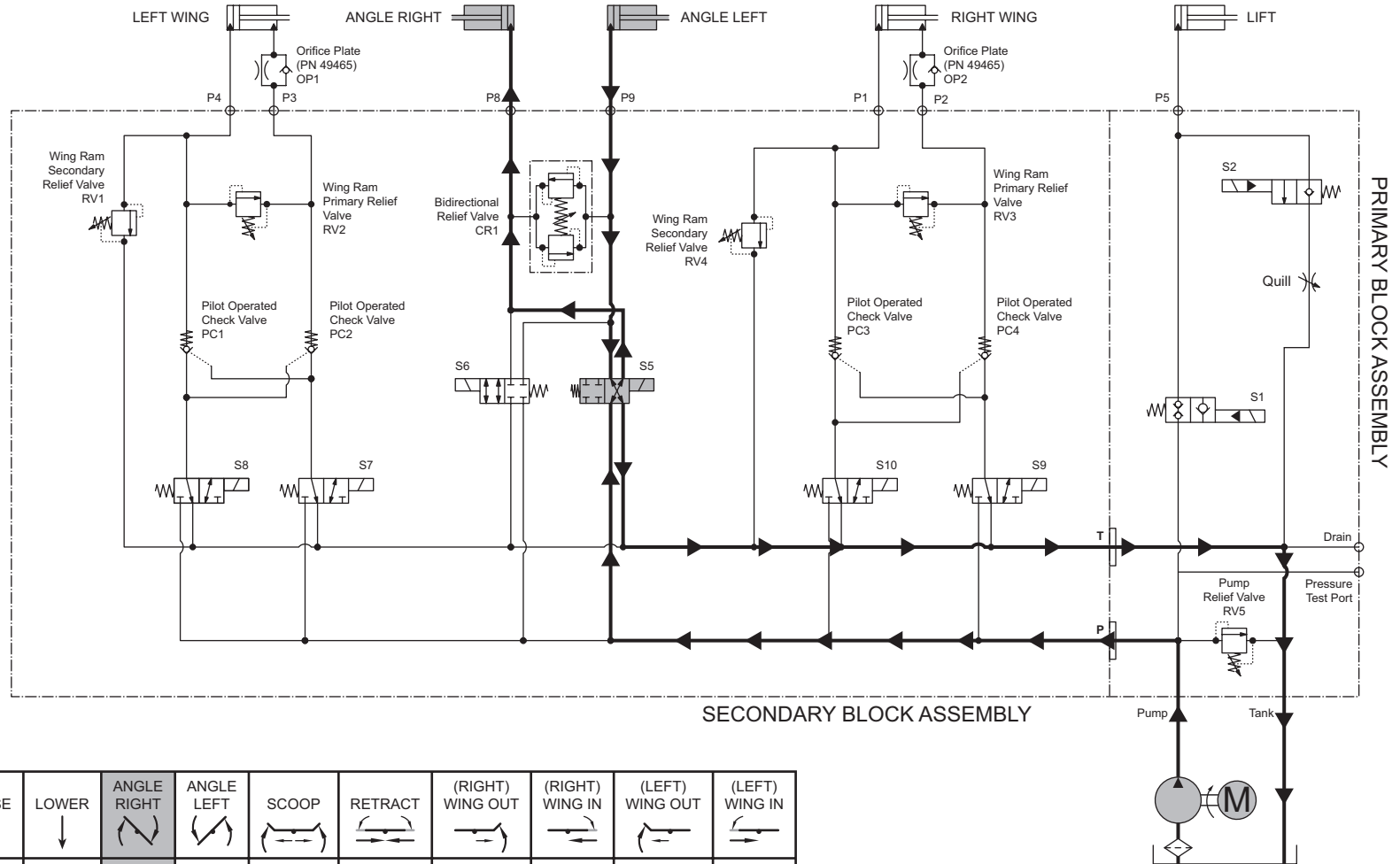

41

BLADE MOVEMENT		RAISE ↑	LOWER ↓	ANGLE RIGHT 	ANGLE LEFT 	SCOOP 	RETRACT 	(RIGHT) WING OUT 	(RIGHT) WING IN 	(LEFT) WING OUT 	(LEFT) WING IN
MOTOR	M	ON		ON	ON	ON	ON	ON	ON	ON	ON
SV08-20	S1	ON									
SV08-2004	S2		ON								
SV08-45	S5			ON							
SV08-41	S6				ON						
SV08-30	S7					ON					ON
SV08-30	S8					ON				ON	
SV08-30	S9					ON		ON			
SV08-30	S10					ON		ON			

Relief Valve Settings	
Pump (RV5)	2250 psi
Wing Ram, Secondary (RV1, RV4)	1700 psi
Wing Ram, Primary (RV2, RV3)	1500 psi

ANGLE LEFT – ELECTRICAL

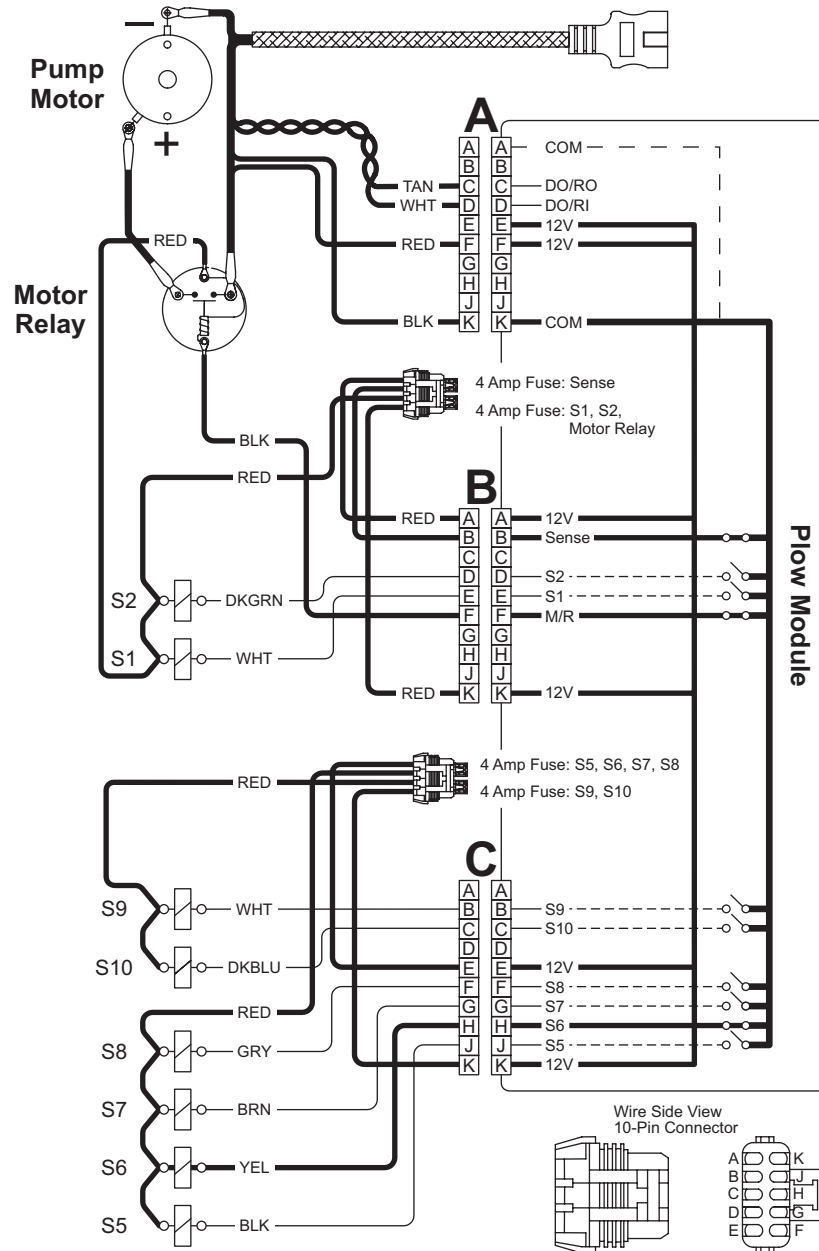

System Response

1. By activating the angle left (L on the control face) function on the cab control, the control sends a signal to the Plow Module to complete the **ground path** for the electrical circuit, activating the motor relay and solenoid cartridge valve S6.
2. Hydraulic fluid from the pump flows through activated S6 and into the base end of the PS cylinder, causing it to extend.

3. The retracting DS ram pushes the hydraulic fluid out of its base end, through activated S6 and back to the reservoir.

NOTE: Battery voltage is supplied to the Plow Module, the motor relay and the 8 solenoid coils when the snowplow is connected to the vehicle.

ANGLE LEFT – HYDRAULIC

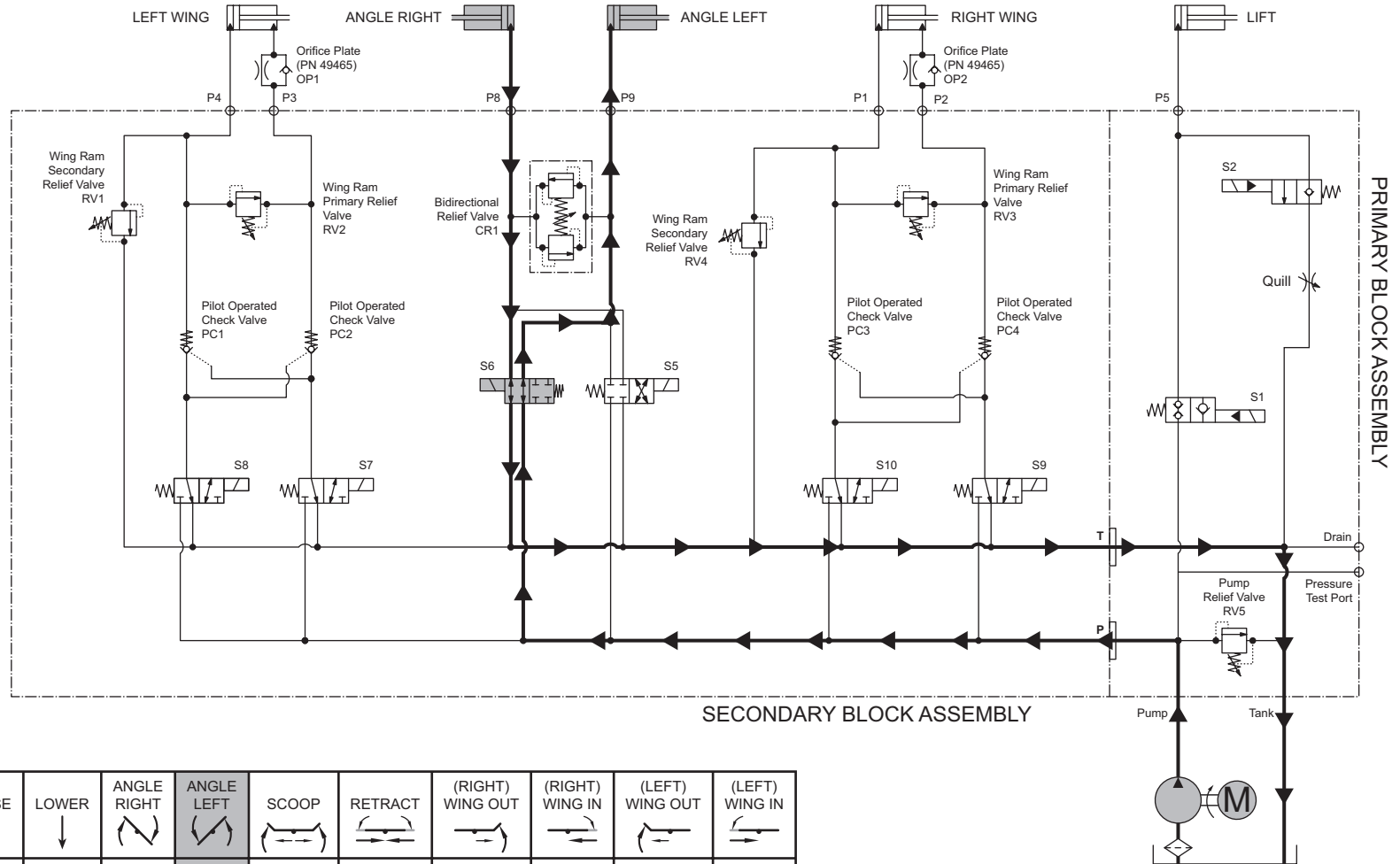

43

BLADE MOVEMENT		RAISE ↑	LOWER ↓	ANGLE RIGHT 	ANGLE LEFT 	SCOOP 	RETRACT 	(RIGHT) WING OUT 	(RIGHT) WING IN 	(LEFT) WING OUT 	(LEFT) WING IN
MOTOR	M	ON		ON	ON	ON	ON	ON	ON	ON	ON
SV08-20	S1	ON									
SV08-2004	S2		ON								
SV08-45	S5			ON							
SV08-41	S6				ON						
SV08-30	S7					ON				ON	
SV08-30	S8					ON				ON	
SV08-30	S9						ON	ON			
SV08-30	S10					ON	ON				

Relief Valve Settings	
Pump (RV5)	2250 psi
Wing Ram, Secondary (RV1, RV4)	1700 psi
Wing Ram, Primary (RV2, RV3)	1500 psi

SCOOP – ELECTRICAL

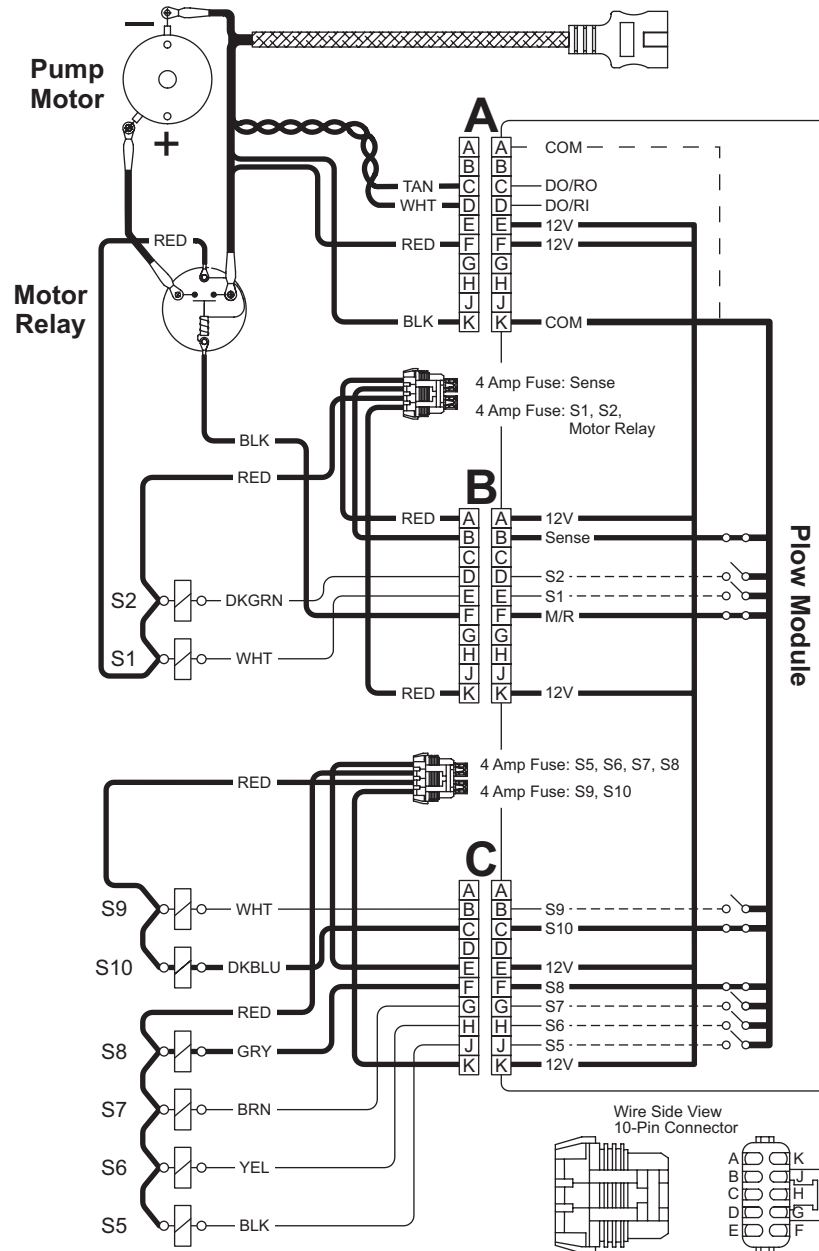

System Response

1. By activating the SCOOP function on the cab control, the control sends a signal to the Plow Module to complete the **ground path** for the electrical circuit, activating the motor relay and solenoid cartridge valves S8 and S10, activating these valves.
2. Hydraulic fluid from the pump flows through activated S8 and S10 and into the base end of the DS angle ram, forcing the rods to extend.
3. Pressure within the hydraulic circuit causes the P/O check valves to open.
4. The extending DS wing ram pushes the hydraulic fluid out of its rod end, through deactivated S7 and back to the reservoir.
5. The extending PS wing ram pushes the hydraulic fluid out of its rod end, through deactivated S9 and back to the reservoir.

NOTE: Battery voltage is supplied to the Plow Module, the motor relay and the 8 solenoid coils when the snowplow is connected to the vehicle.

SCOOP – HYDRAULIC

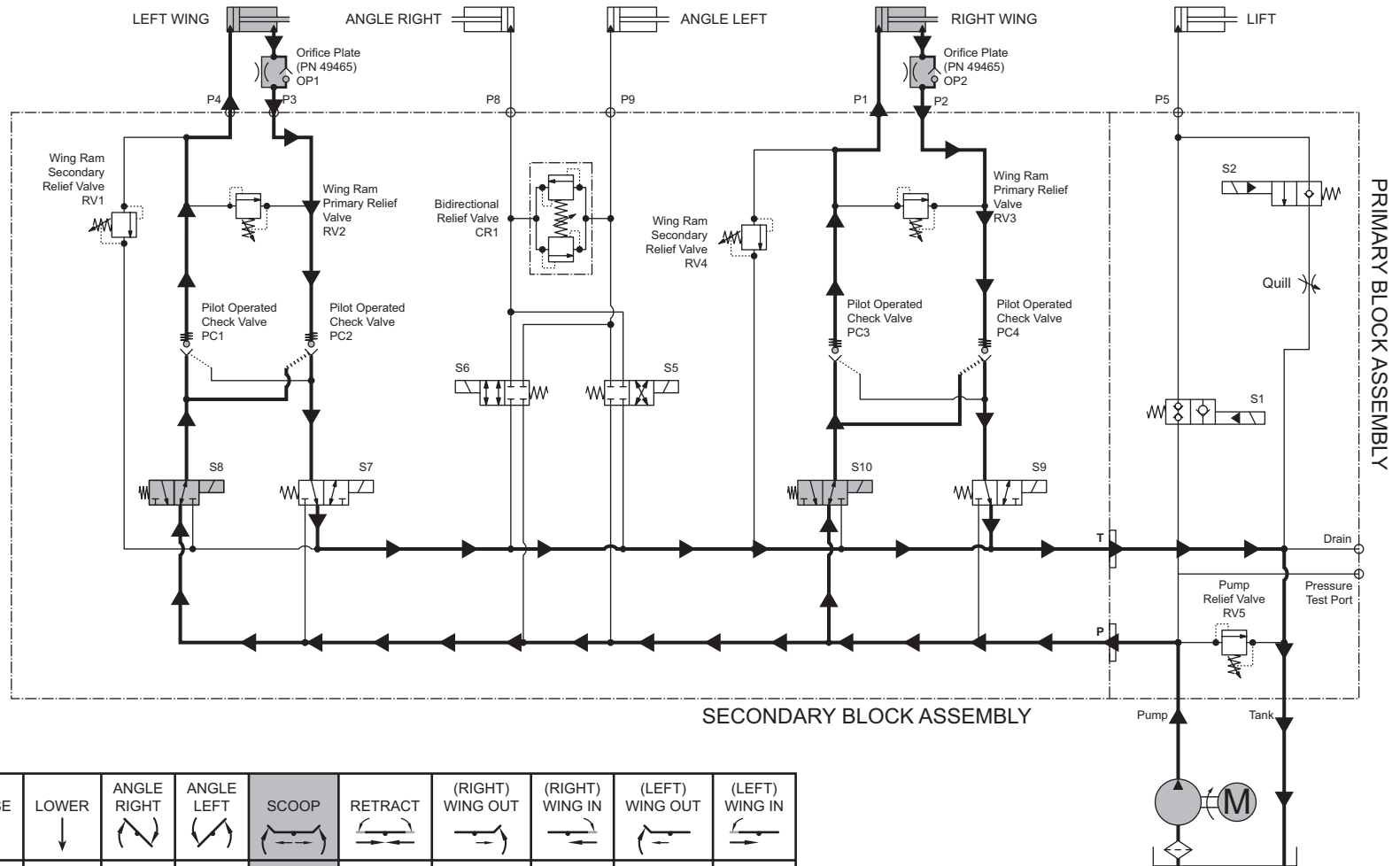

45

BLADE MOVEMENT		RAISE ↑	LOWER ↓	ANGLE RIGHT 	ANGLE LEFT 	SCOOP 	RETRACT 	(RIGHT) WING OUT 	(RIGHT) WING IN 	(LEFT) WING OUT 	(LEFT) WING IN
MOTOR	M	ON		ON	ON	ON	ON	ON	ON	ON	ON
SV08-20	S1	ON									
SV08-2004	S2		ON								
SV08-45	S5			ON							
SV08-41	S6				ON						
SV08-30	S7					ON					ON
SV08-30	S8					ON				ON	
SV08-30	S9						ON	ON			
SV08-30	S10					ON		ON			

Relief Valve Settings	
Pump (RV5)	2250 psi
Wing Ram, Secondary (RV1, RV4)	1700 psi
Wing Ram, Primary (RV2, RV3)	1500 psi

RETRACT – ELECTRICAL

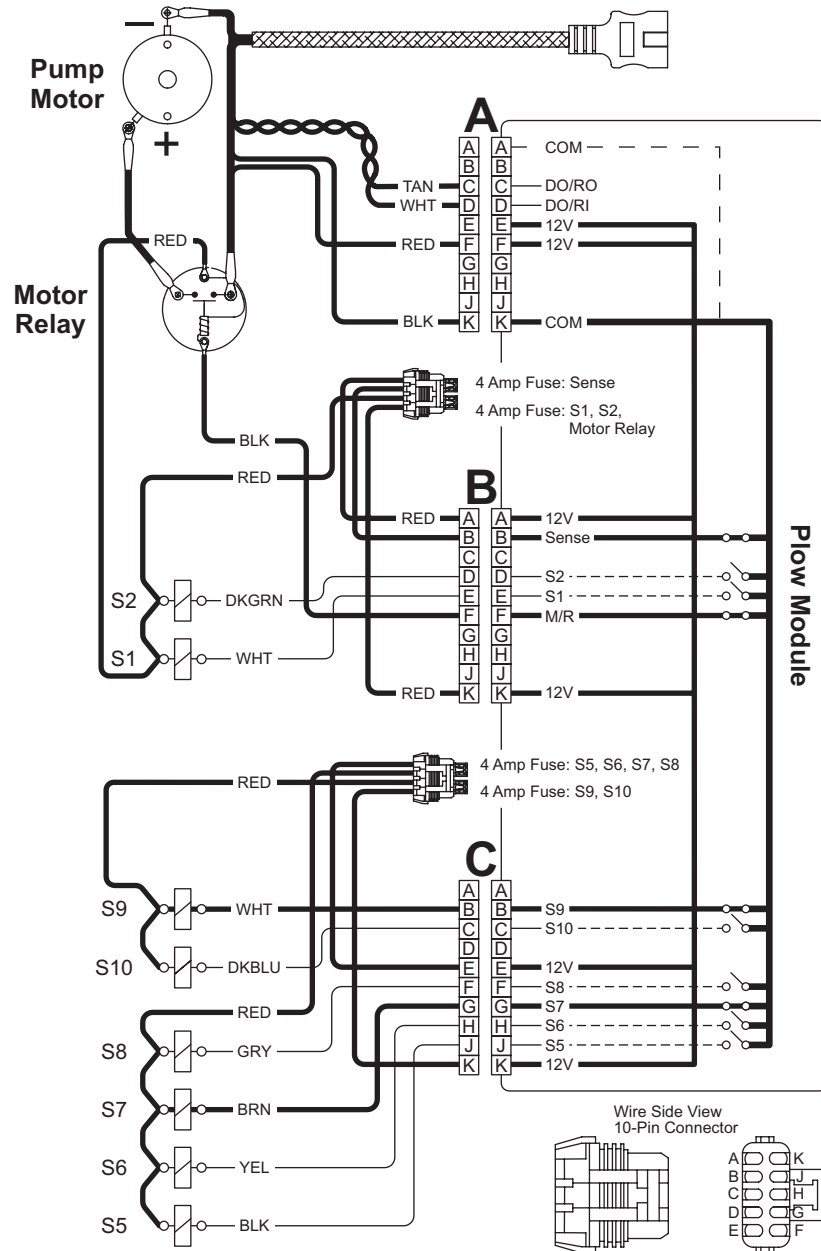

System Response

1. By activating the RETRACT function on the cab control, the control sends a signal to the Plow Module to complete the **ground path** for the electrical circuit, activating the motor relay and solenoid cartridge valves S7 and S9.
2. Hydraulic fluid from the pump flows through activated S7 & S9, then into the rod end of the DS and PS wing rams, causing the rams to retract.
3. Pressure within the hydraulic circuit causes the P/O check valves to open.
4. The retracting DS wing ram pushes the hydraulic fluid out of its base end, through deactivated S8 and back to the reservoir.
5. The retracting PS wing ram pushes the hydraulic fluid out of its base end, through deactivated S10 and back to the reservoir.

NOTE: Battery voltage is supplied to the Plow Module, the motor relay and the 8 solenoid coils when the snowplow is connected to the vehicle.

RETRACT – HYDRAULIC

There is a hexagonal orifice plate under each of the two wing rod fittings at the manifold. The slot in the orifice plate must face the manifold.

Installing orifice plates backwards will cause blade wings to "chatter" when retracting.

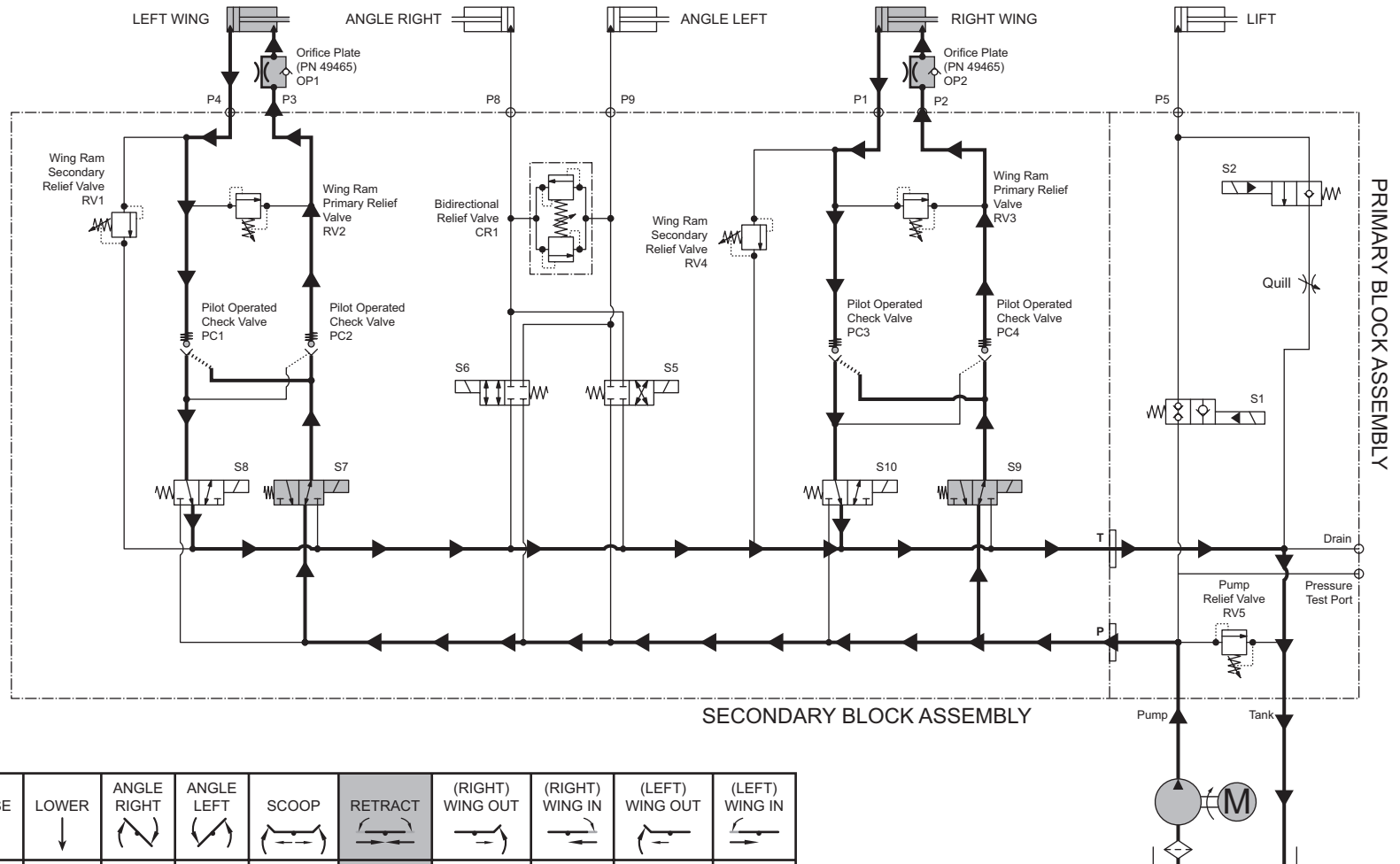

BLADE MOVEMENT		RAISE ↑	LOWER ↓	ANGLE RIGHT 	ANGLE LEFT 	SCOOP 	RETRACT 	(RIGHT) WING OUT 	(RIGHT) WING IN 	(LEFT) WING OUT 	(LEFT) WING IN
MOTOR	M	ON		ON	ON	ON	ON	ON	ON	ON	ON
SV08-20	S1	ON									
SV08-2004	S2		ON								
SV08-45	S5			ON							
SV08-41	S6				ON						
SV08-30	S7					ON					ON
SV08-30	S8					ON				ON	
SV08-30	S9					ON	ON				
SV08-30	S10					ON	ON				

Relief Valve Settings	
Pump (RV5)	2250 psi
Wing Ram, Secondary (RV1, RV4)	1700 psi
Wing Ram, Primary (RV2, RV3)	1500 psi

RIGHT WING OUT – ELECTRICAL

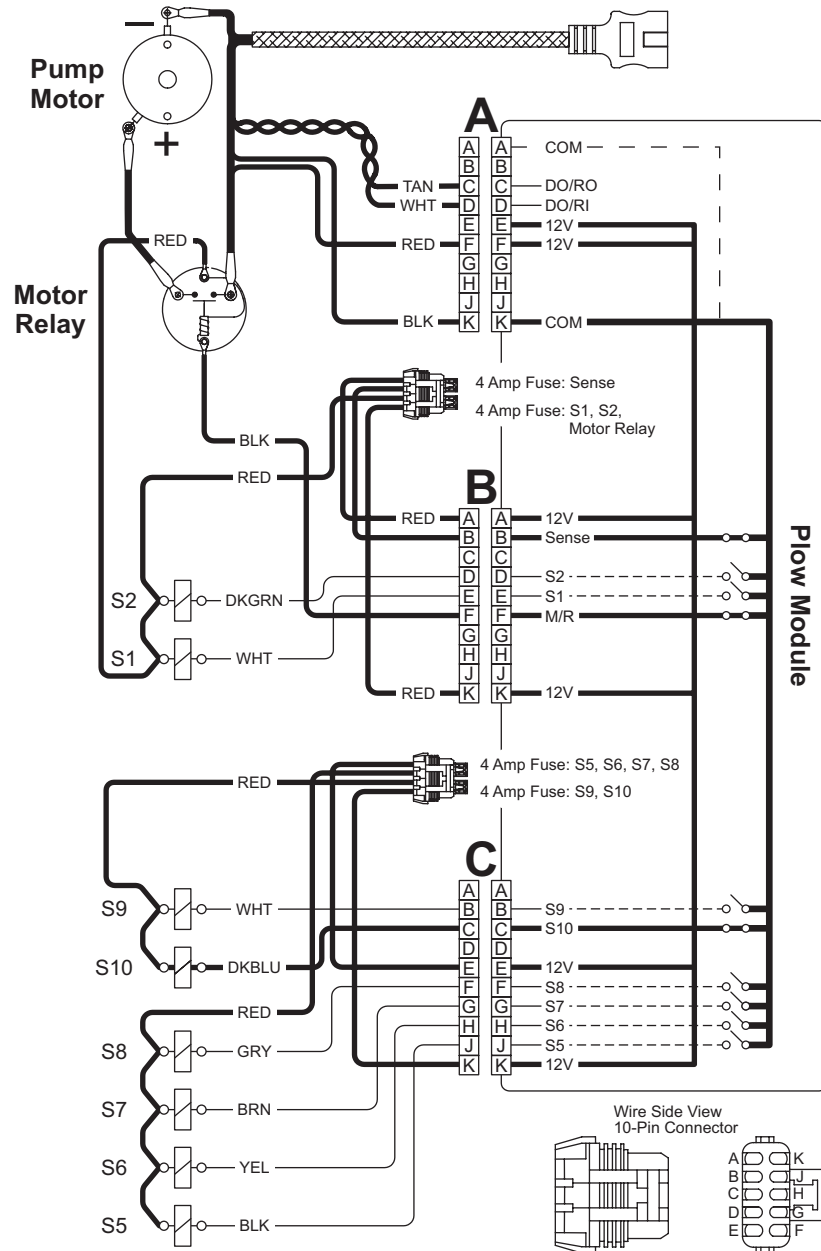

System Response

1. By activating the WING OUT function on the right side of the cab control, the control sends a signal to the Plow Module to complete the **ground path** for the electrical circuit, activating the motor relay and solenoid cartridge valve S10. The wing mode toggles between extend and retract.
3. Pressure within the hydraulic circuit causes the P/O check valve to open.
4. The extending PS wing ram pushes the hydraulic fluid out of its rod end, through deactivated S9 and back to the reservoir.

NOTE: See the System Overview – Controls Section for operation information.

NOTE: Battery voltage is supplied to the Plow Module, the motor relay and the 8 solenoid coils when the snowplow is connected to the vehicle.

2. Hydraulic fluid from the pump flows through activated S10 into the base end of the PS wing ram, causing it to extend.

RIGHT WING OUT – HYDRAULIC

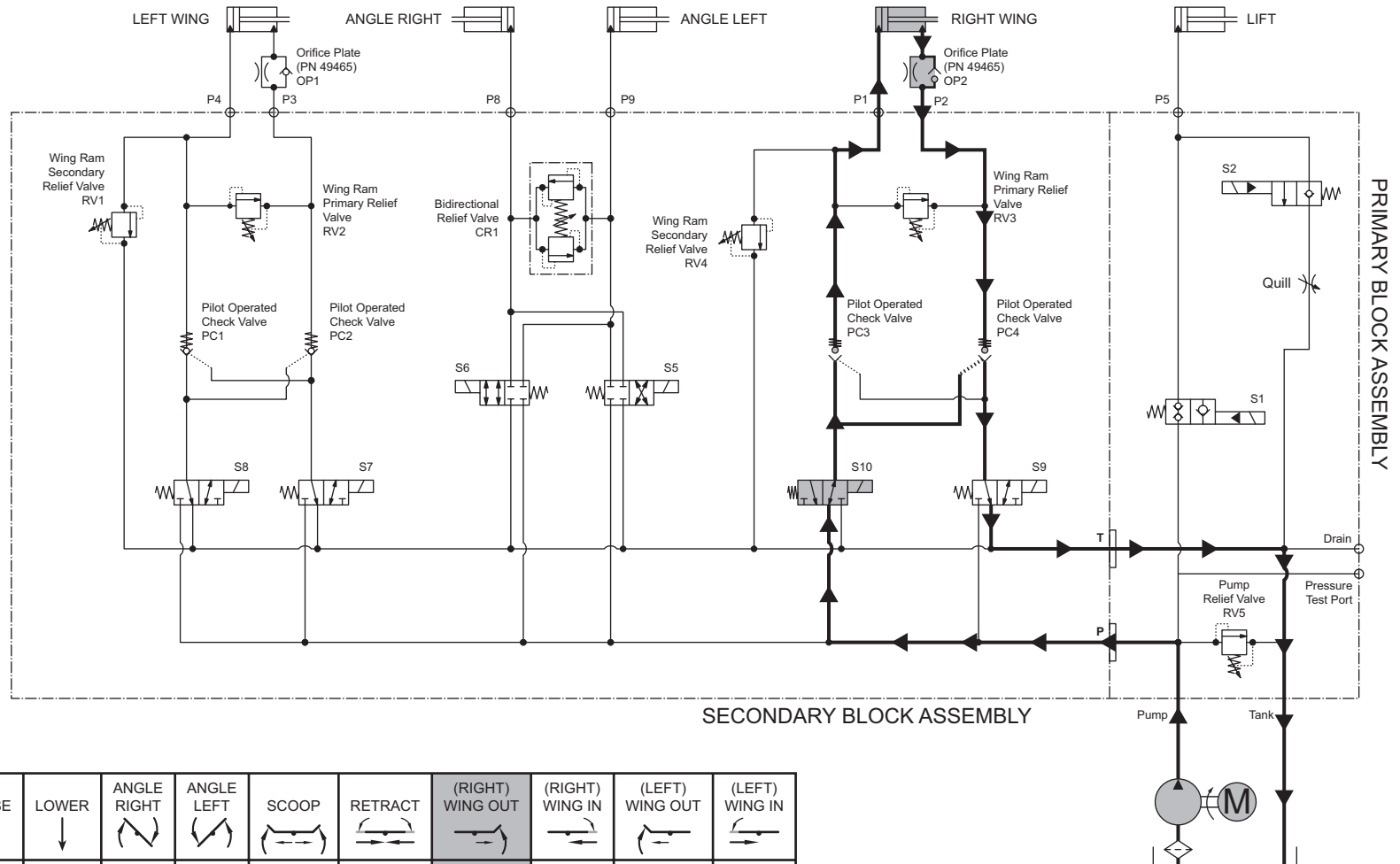

BLADE MOVEMENT		RAISE ↑	LOWER ↓	ANGLE RIGHT 	ANGLE LEFT 	SCOOP 	RETRACT 	(RIGHT) WING OUT 	(RIGHT) WING IN 	(LEFT) WING OUT 	(LEFT) WING IN
MOTOR	M	ON		ON	ON	ON	ON	ON	ON	ON	ON
SV08-20	S1	ON									
SV08-2004	S2		ON								
SV08-45	S5			ON							
SV08-41	S6				ON						
SV08-30	S7					ON					ON
SV08-30	S8					ON				ON	
SV08-30	S9					ON		ON			
SV08-30	S10					ON		ON			

Relief Valve Settings	
Pump (RV5)	2250 psi
Wing Ram, Secondary (RV1, RV4)	1700 psi
Wing Ram, Primary (RV2, RV3)	1500 psi

RIGHT WING IN – ELECTRICAL

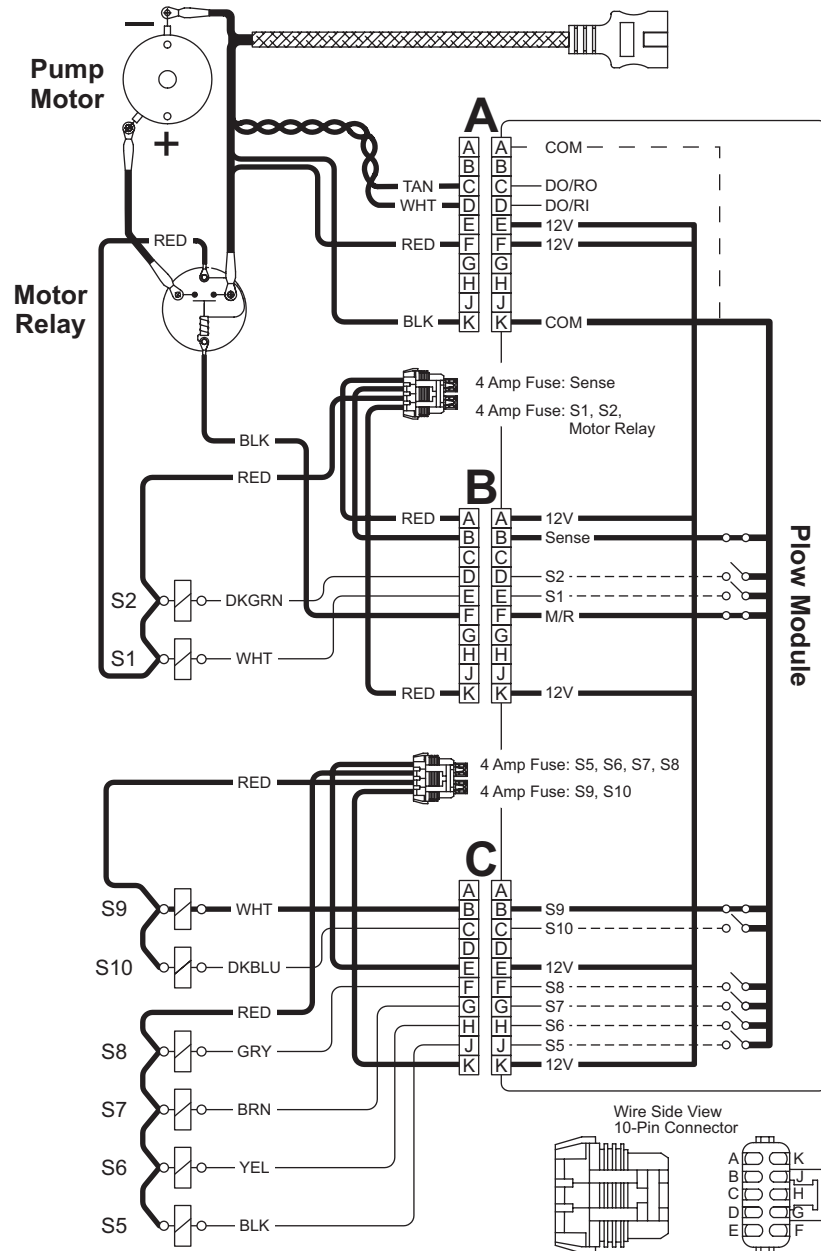

System Response

1. By activating the WING IN function on the right side of the cab control, the control sends a signal to the Plow Module to complete the **ground path** for the electrical circuit, activating the motor relay and solenoid cartridge valves S9. The wing mode toggles between extend and retract.
3. Pressure within the hydraulic circuit causes the P/O check valve to open.
4. The retracting PS wing ram pushes the hydraulic fluid out of its base end, through deactivated S10 and back to the reservoir.

NOTE: See the System Overview – Controls Section for operation information.

NOTE: Battery voltage is supplied to the Plow Module, the motor relay and the 8 solenoid coils when the snowplow is connected to the vehicle.

2. Hydraulic fluid from the pump flows through activated S9 into the rod end of the PS wing ram, causing it to retract.

RIGHT WING IN – HYDRAULIC

There is a hexagonal orifice plate under each of the two wing rod fittings at the manifold. The slot in the orifice plate must face the manifold.

Installing orifice plates backwards will cause blade wings to "chatter" when retracting.

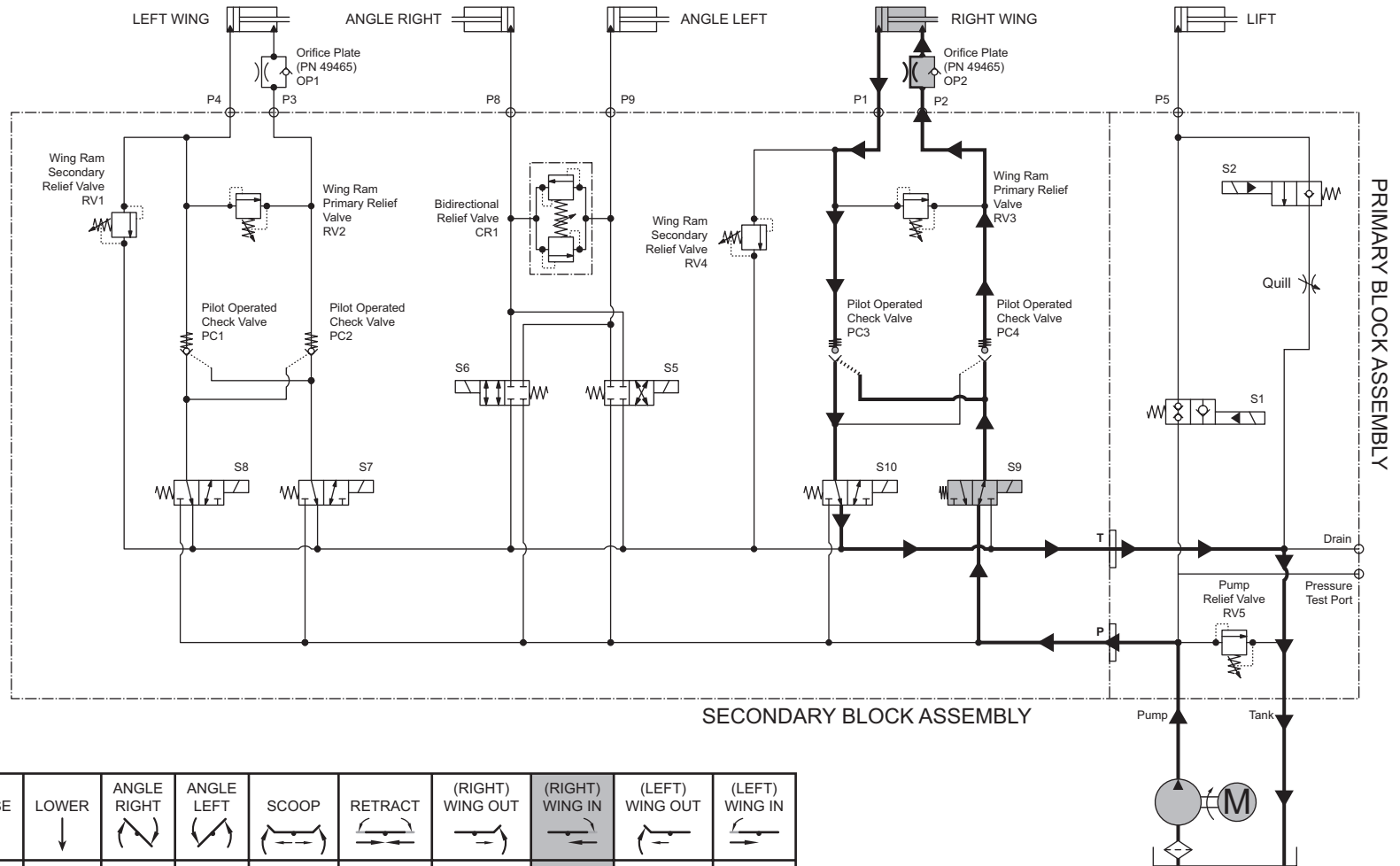

BLADE MOVEMENT		RAISE ↑	LOWER ↓	ANGLE RIGHT 	ANGLE LEFT 	SCOOP 	RETRACT 	(RIGHT) WING OUT 	(RIGHT) WING IN 	(LEFT) WING OUT 	(LEFT) WING IN
MOTOR	M	ON		ON	ON	ON	ON	ON	ON	ON	ON
SVCV08-20	S1	ON									
SV08-2004	S2		ON								
SV08-45	S5			ON							
SV08-41	S6				ON						
SV08-30	S7					ON					ON
SV08-30	S8					ON				ON	
SV08-30	S9					ON		ON			
SV08-30	S10					ON	ON				

Relief Valve Settings	
Pump (RV5)	2250 psi
Wing Ram, Secondary (RV1, RV4)	1700 psi
Wing Ram, Primary (RV2, RV3)	1500 psi

LEFT WING OUT – ELECTRICAL

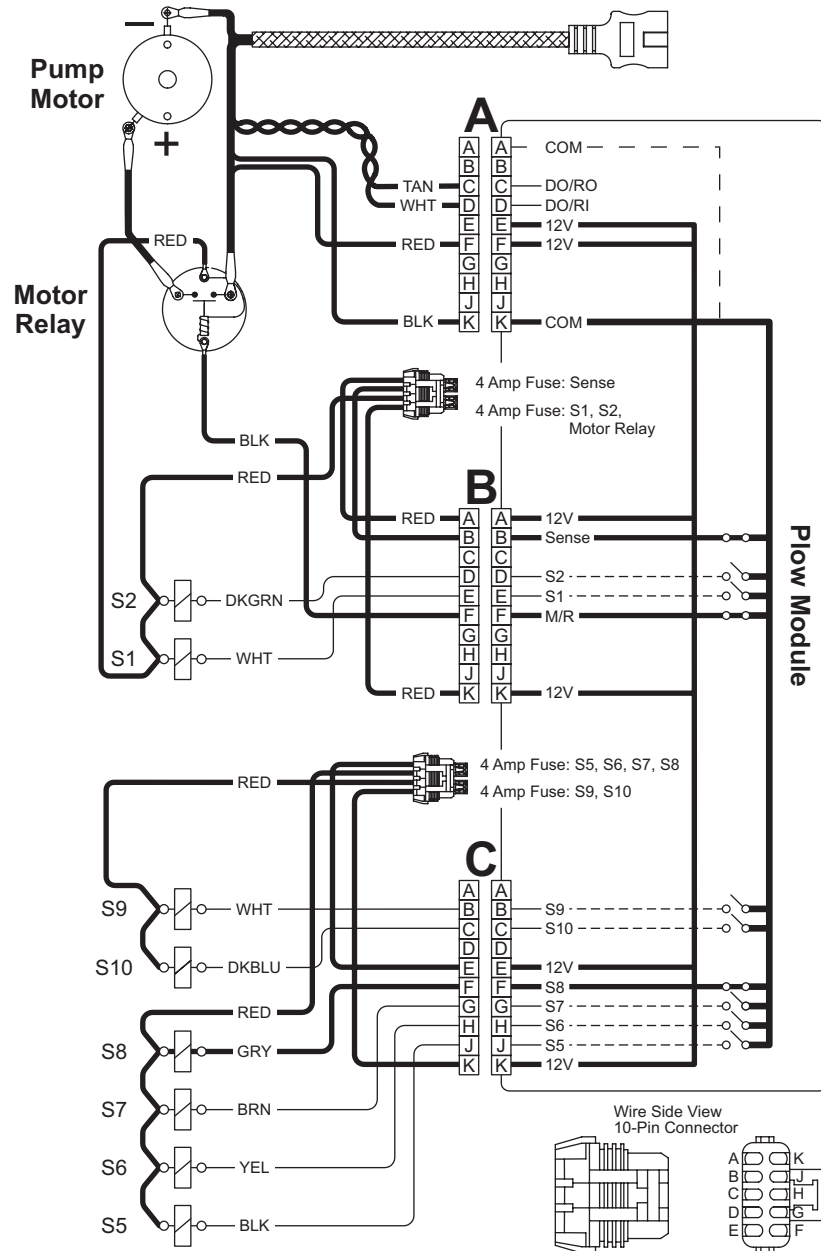

System Response

1. By activating the WING OUT function on the left side of the cab control, the control sends a signal to the Plow Module to complete the **ground path** for the electrical circuit, activating the motor relay and solenoid cartridge valve S8. The wing mode toggles between extend and retract.
3. Pressure within the hydraulic circuit causes the P/O check valves to open.
4. The extending DS wing ram pushes the hydraulic fluid out of its rod end, through deactivated S7 and back to the reservoir.

NOTE: See the System Overview – Controls Section for operation information.

NOTE: Battery voltage is supplied to the Plow Module, the motor relay and the 8 solenoid coils when the snowplow is connected to the vehicle.

2. Hydraulic fluid from the pump flows through activated S8 into the base end of the DS ram, causing it to extend.

LEFT WING OUT – HYDRAULIC

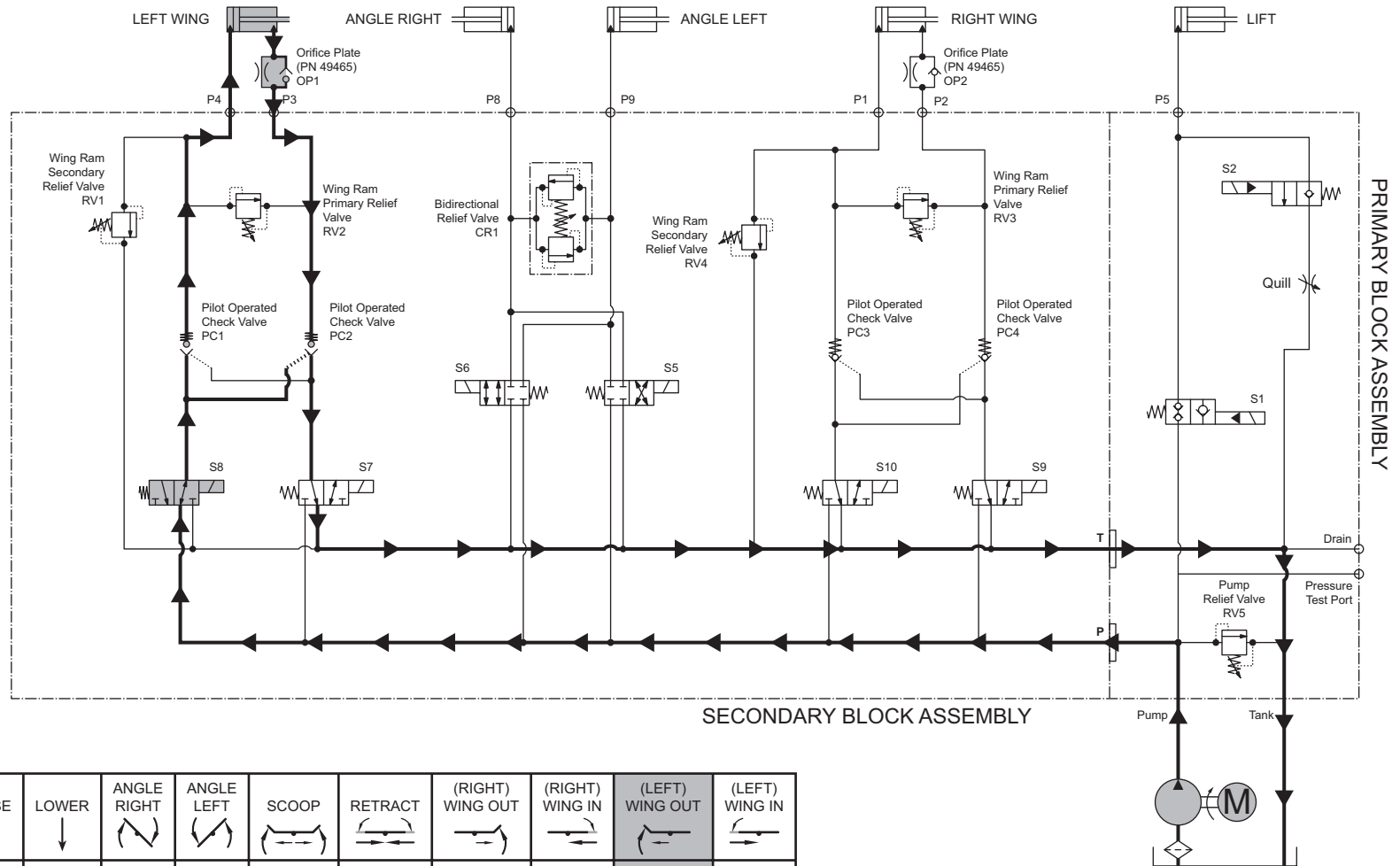

BLADE MOVEMENT		RAISE ↑	LOWER ↓	ANGLE RIGHT 	ANGLE LEFT 	SCOOP 	RETRACT 	(RIGHT) WING OUT 	(RIGHT) WING IN 	(LEFT) WING OUT 	(LEFT) WING IN
MOTOR	M	ON		ON	ON	ON	ON	ON	ON	ON	ON
SV08-20	S1	ON									
SV08-2004	S2		ON								
SV08-45	S5			ON							
SV08-41	S6				ON						
SV08-30	S7					ON					ON
SV08-30	S8					ON				ON	
SV08-30	S9						ON	ON			
SV08-30	S10						ON	ON			

Relief Valve Settings	
Pump (RV5)	2250 psi
Wing Ram, Secondary (RV1, RV4)	1700 psi
Wing Ram, Primary (RV2, RV3)	1500 psi

LEFT WING IN – ELECTRICAL

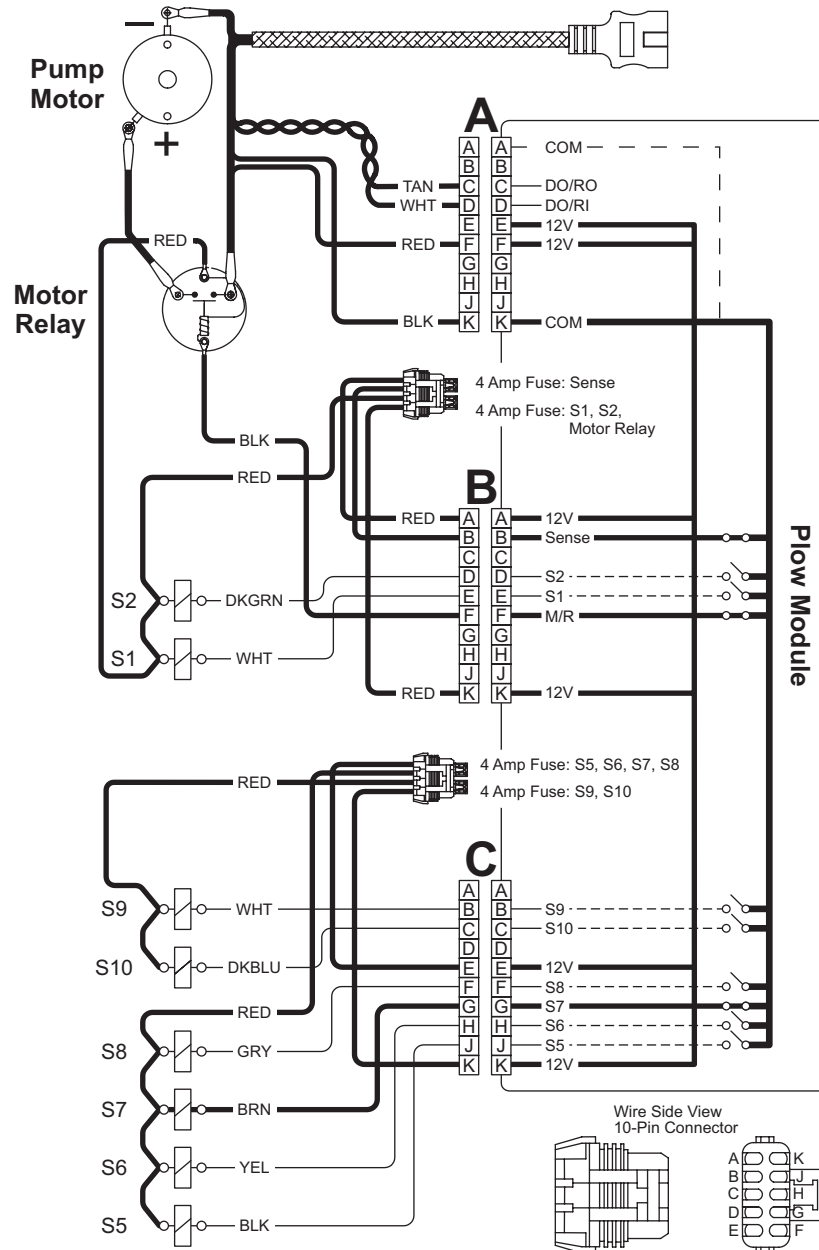

System Response

1. By activating the WING IN function on the left side of the cab control, the control sends a signal to the Plow Module to complete the **ground path** for the electrical circuit, activating the motor relay and solenoid cartridge valve S7. The wing mode toggles between extend and retract.
3. Pressure within the hydraulic circuit causes the P/O check valve to open.
4. The retracting DS wing ram pushes the hydraulic fluid out of its base end, through deactivated S8 and back to the reservoir.

NOTE: See the System Overview – Controls Section for operation information.

NOTE: Battery voltage is supplied to the Plow Module, the motor relay and the 8 solenoid coils when the snowplow is connected to the vehicle.

2. Hydraulic fluid from the pump flows through activated S7 into the rod end of the DS wing ram, causing it to retract.

LEFT WING IN – HYDRAULIC

There is a hexagonal orifice plate under each of the two wing rod fittings at the manifold. The slot in the orifice plate must face the manifold.

Installing orifice plates backwards will cause blade wings to "chatter" when retracting.

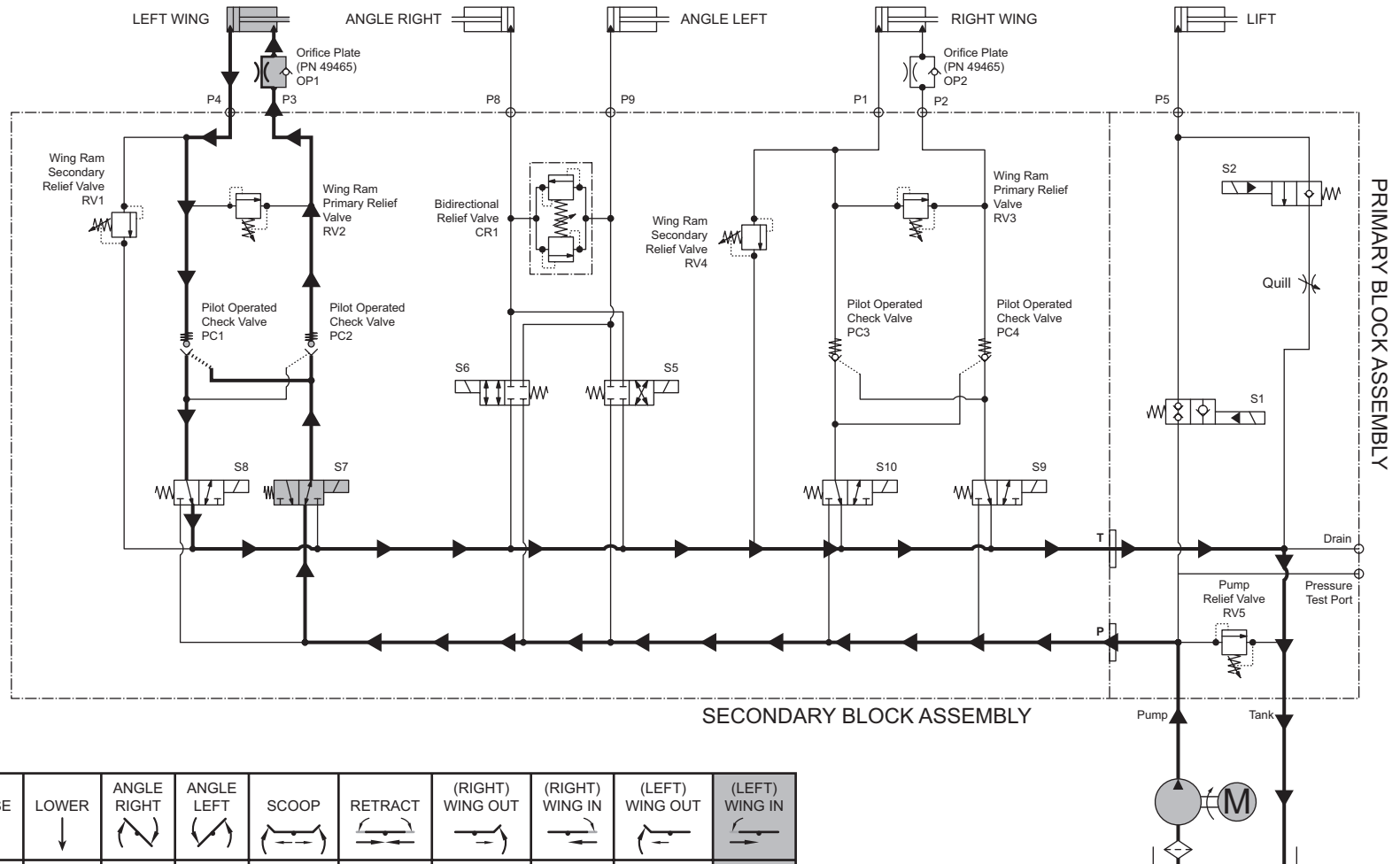

BLADE MOVEMENT		RAISE ↑	LOWER ↓	ANGLE RIGHT 	ANGLE LEFT 	SCOOP 	RETRACT 	(RIGHT) WING OUT 	(RIGHT) WING IN 	(LEFT) WING OUT 	(LEFT) WING IN
MOTOR	M	ON		ON	ON	ON	ON	ON	ON	ON	ON
SV08-20	S1	ON									
SV08-2004	S2		ON								
SV08-45	S5			ON							
SV08-41	S6				ON						
SV08-30	S7					ON					ON
SV08-30	S8					ON				ON	
SV08-30	S9						ON	ON			
SV08-30	S10						ON	ON			

Relief Valve Settings	
Pump (RV5)	2250 psi
Wing Ram, Secondary (RV1, RV4)	1700 psi
Wing Ram, Primary (RV2, RV3)	1500 psi

HOLD IN RAISE POSITION – HYDRAULIC

System Response

1. Hydraulic fluid is trapped in the base end of the lift ram by the internal check valve in solenoid cartridge valves S1 & S2.

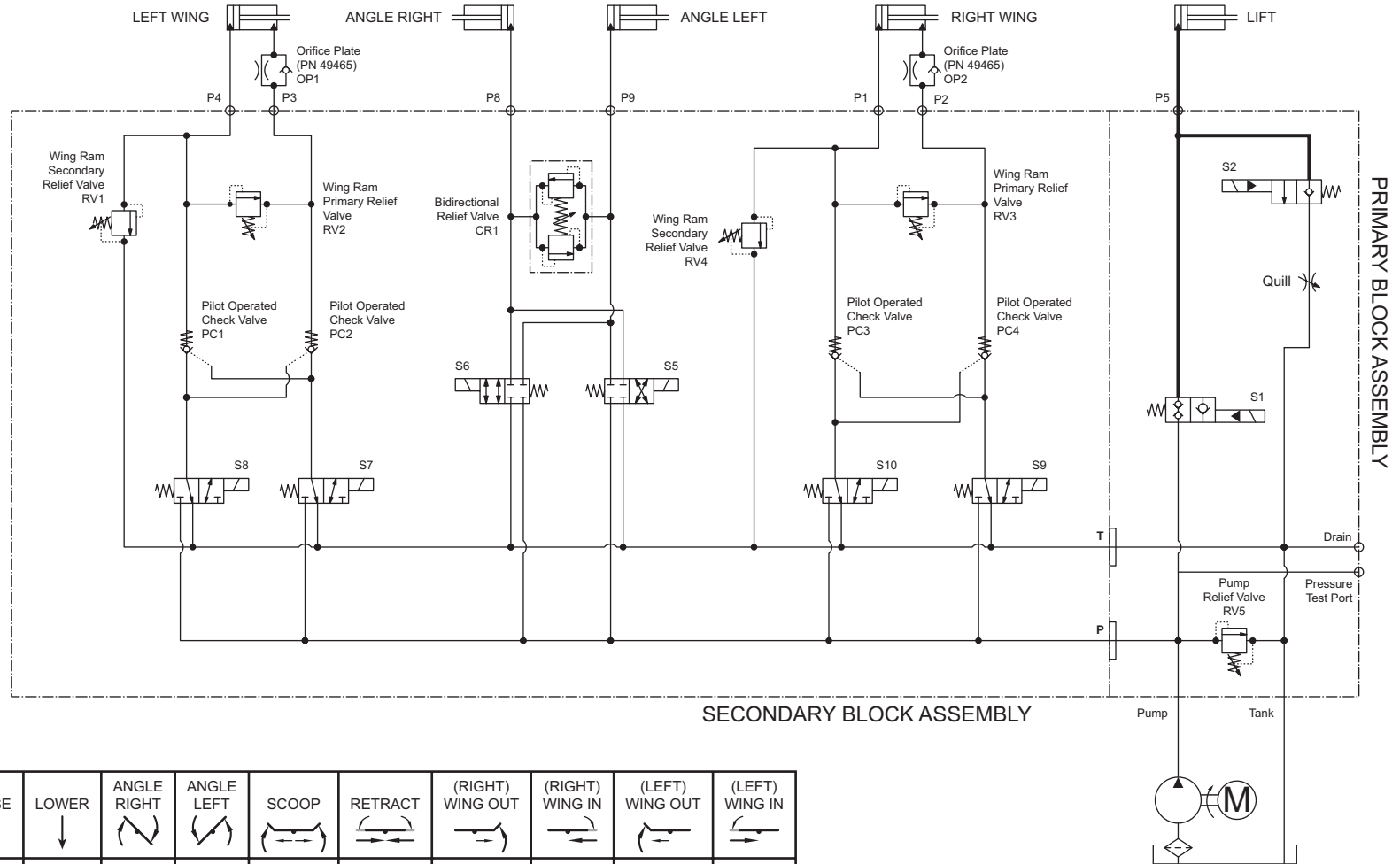

BLADE MOVEMENT		RAISE ↑	LOWER ↓	ANGLE RIGHT 	ANGLE LEFT 	SCOOP 	RETRACT 	(RIGHT) WING OUT 	(RIGHT) WING IN 	(LEFT) WING OUT 	(LEFT) WING IN
MOTOR	M	ON		ON	ON	ON	ON	ON	ON	ON	ON
SV08-20	S1	ON									
SV08-2004	S2		ON								
SV08-45	S5			ON							
SV08-41	S6				ON						
SV08-30	S7					ON					ON
SV08-30	S8					ON				ON	
SV08-30	S9					ON		ON			
SV08-30	S10					ON		ON			

Relief Valve Settings	
Pump (RV5)	2250 psi
Wing Ram, Secondary (RV1, RV4)	1700 psi
Wing Ram, Primary (RV2, RV3)	1500 psi

STRIKING AN OBJECT WHILE PLOWING FORWARD – HYDRAULIC (DS)

System Response

1. Hydraulic fluid is trapped in the base end of the cylinder by the inactivated S6 solenoid cartridge valve and the bidirectional relief valve.
2. When the snowplow contacts an object while plowing, force of the impact increases hydraulic pressure in the base end of the cylinder. When pressure exceeds the nominal setting value of the bidirectional relief valve, it opens allowing hydraulic fluid to flow to the base end of the opposite cylinder.

The bidirectional relief valve is not adjustable.

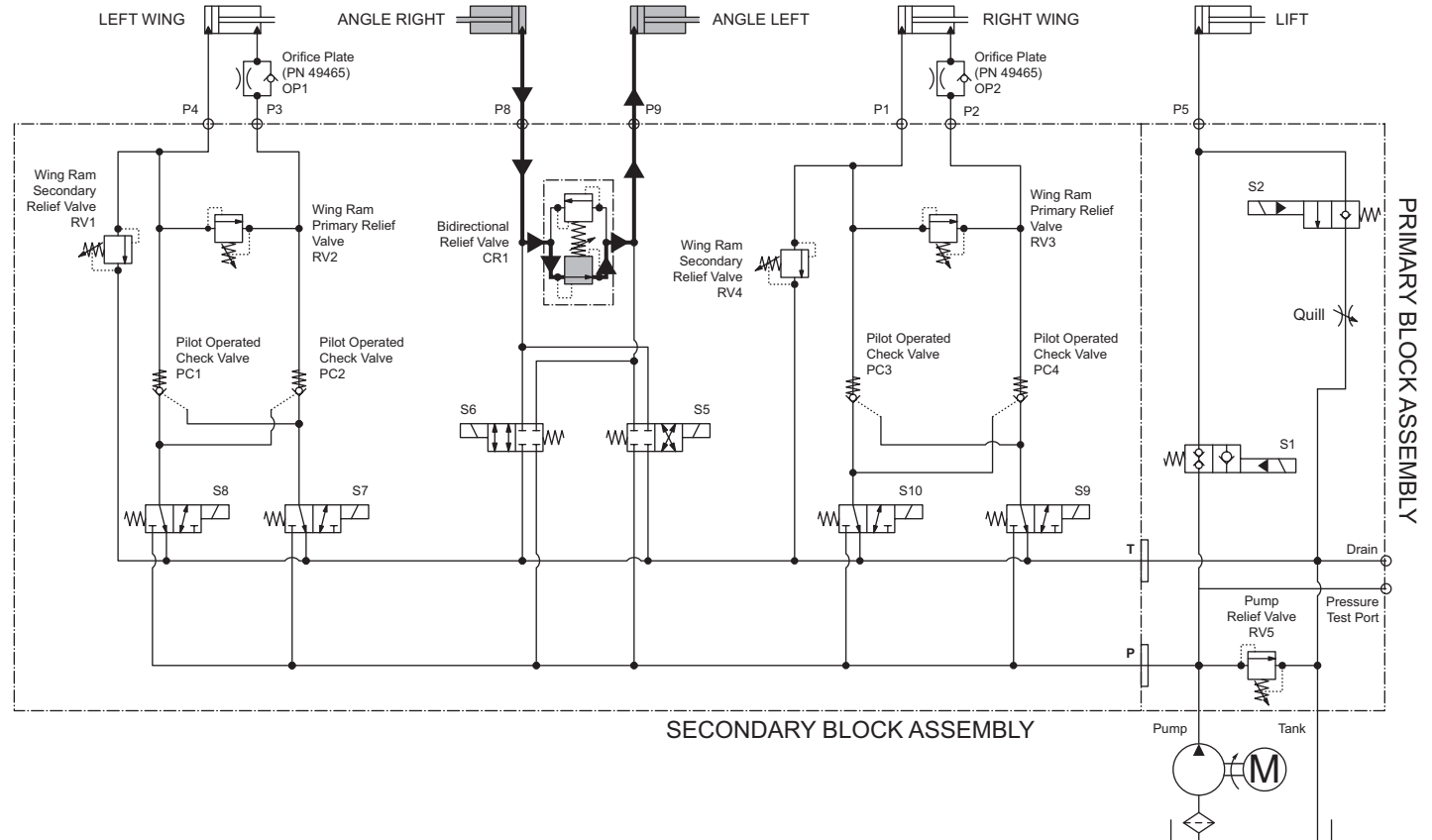

Relief Valve Settings	
Pump (RV5)	2250 psi
Wing Ram, Secondary (RV1, RV4)	1700 psi
Wing Ram, Primary (RV2, RV3)	1500 psi

BLADE MOVEMENT		RAISE ↑	LOWER ↓	ANGLE RIGHT 	ANGLE LEFT 	SCOOP 	RETRACT 	(RIGHT) WING OUT 	(RIGHT) WING IN 	(LEFT) WING OUT 	(LEFT) WING IN
MOTOR	M	ON		ON	ON	ON	ON	ON	ON	ON	ON
SVCV08-20	S1	ON									
SV08-2004	S2		ON								
SV08-45	S5			ON							
SV08-41	S6				ON						
SV08-30	S7					ON					ON
SV08-30	S8					ON				ON	
SV08-30	S9					ON		ON			
SV08-30	S10					ON		ON			

STRIKING AN OBJECT WHILE PLOWING FORWARD – HYDRAULIC (PS)

System Response

1. Hydraulic fluid is trapped in the base end of the cylinder by the inactivated S5 solenoid cartridge valve and the bidirectional relief valve.
2. When the snowplow contacts an object while plowing, force of the impact increases hydraulic pressure in the base end of the cylinder. When pressure exceeds the nominal setting value of the bidirectional relief valve, it opens allowing hydraulic fluid to flow to the base end of the opposite cylinder.

The bidirectional relief valve is not adjustable.

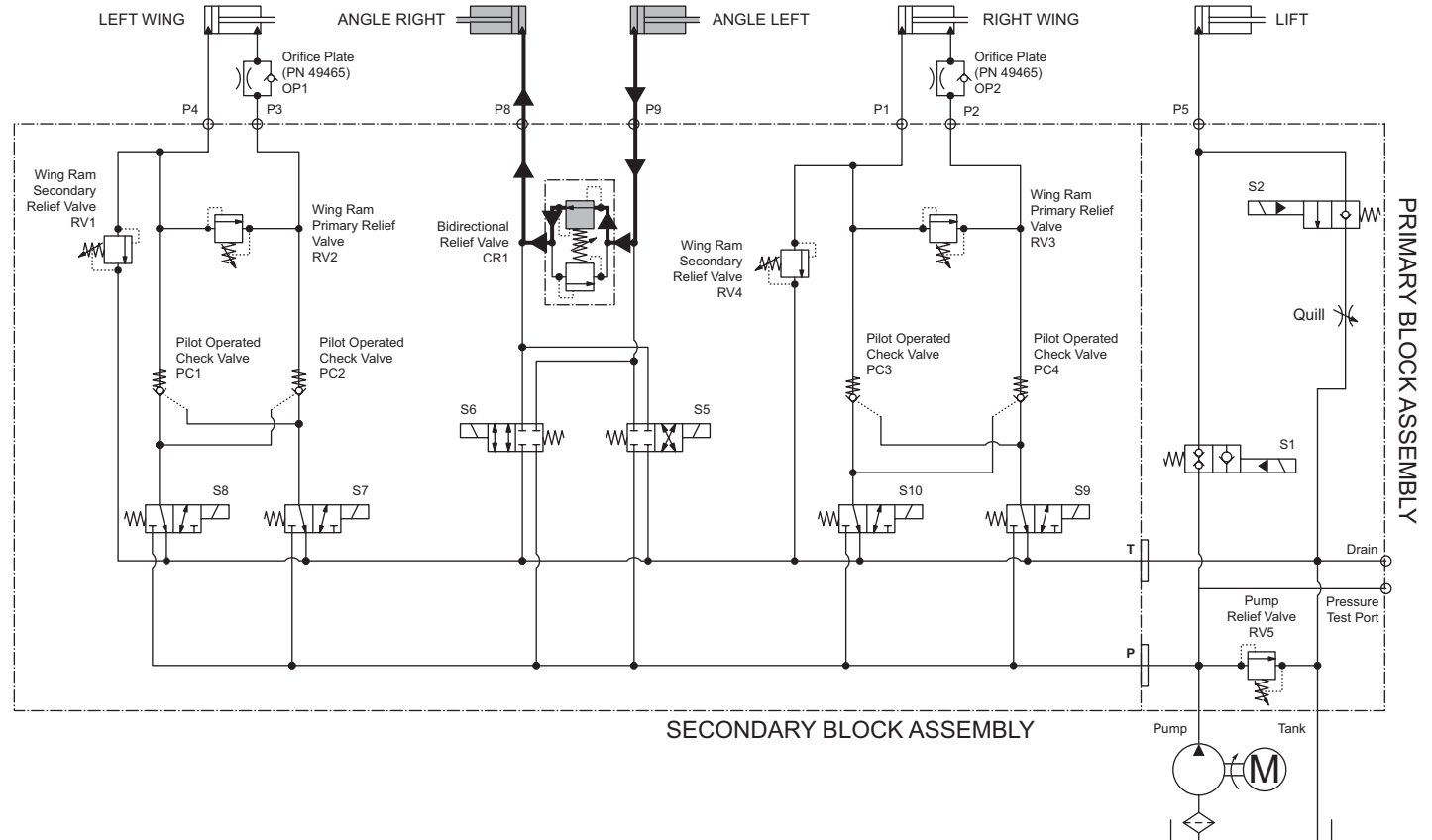

Relief Valve Settings	
Pump (RV5)	2250 psi
Wing Ram, Secondary (RV1, RV4)	1700 psi
Wing Ram, Primary (RV2, RV3)	1500 psi

BLADE MOVEMENT		RAISE ↑	LOWER ↓	ANGLE RIGHT 	ANGLE LEFT 	SCOOP 	RETRACT 	(RIGHT) WING OUT 	(RIGHT) WING IN 	(LEFT) WING OUT 	(LEFT) WING IN
MOTOR	M	ON		ON	ON	ON	ON	ON	ON	ON	ON
SVCV08-20	S1	ON									
SV08-2004	S2		ON								
SV08-45	S5			ON							
SV08-41	S6				ON						
SV08-30	S7					ON					ON
SV08-30	S8					ON				ON	
SV08-30	S9					ON		ON			
SV08-30	S10					ON		ON			

STRIKING AN OBJECT W/WINGS IN SCOOP POSITION WHILE PLOWING FORWARD – HYDRAULIC

System Response

- Hydraulic fluid is trapped in the base end of the DS cylinder by the right primary relief valve, right secondary relief valve and the P/O check valve. Hydraulic fluid is trapped in the base end of the PS cylinder by the left primary relief valve, left secondary relief valve and the P/O check valve.
- When the snowplow contacts an object on the front side of either wing, the force of the impact increases hydraulic pressure in the base end of one cylinder. When pressure exceeds 1500 psi, the cylinder's primary relief valve opens allowing some of the hydraulic fluid to move from the base end to the rod end of the same cylinder.
- Due to the unequal displacement of fluid between the base and rod ends of the cylinder, hydraulic pressure continues to increase. When the pressure exceeds 1700 psi, the cylinder's secondary relief valve opens allowing the remaining hydraulic fluid to flow back to the reservoir.

The wings will not relieve when back dragging.

Relief Valve Settings	
Pump (RV5)	2250 psi
Wing Ram, Secondary (RV1, RV4)	1700 psi
Wing Ram, Primary (RV2, RV3)	1500 psi

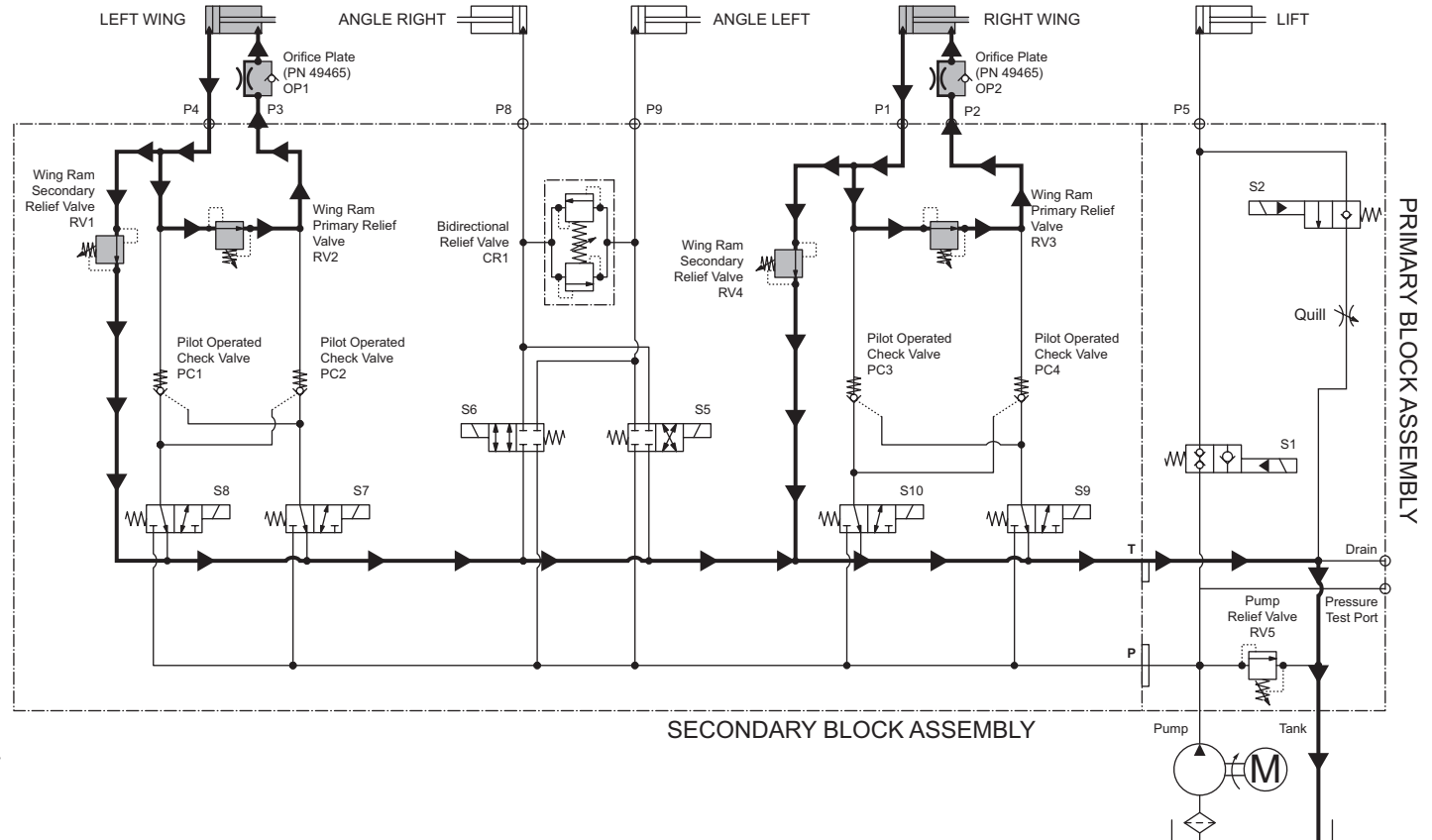

BLADE MOVEMENT		RAISE ↑	LOWER ↓	ANGLE RIGHT 	ANGLE LEFT 	SCOOP 	RETRACT 	(RIGHT) WING OUT 	(RIGHT) WING IN 	(LEFT) WING OUT 	(LEFT) WING IN
MOTOR	M	ON		ON	ON	ON	ON	ON	ON	ON	ON
SVCV08-20	S1	ON									
SV08-2004	S2		ON								
SV08-45	S5			ON							
SV08-41	S6				ON						
SV08-30	S7					ON					ON
SV08-30	S8					ON				ON	
SV08-30	S9					ON		ON			
SV08-30	S10					ON		ON			

LOW BEAM HEADLAMPS WITH SNOWPLOW CONNECTED TO VEHICLE (4-PORT MODULE)

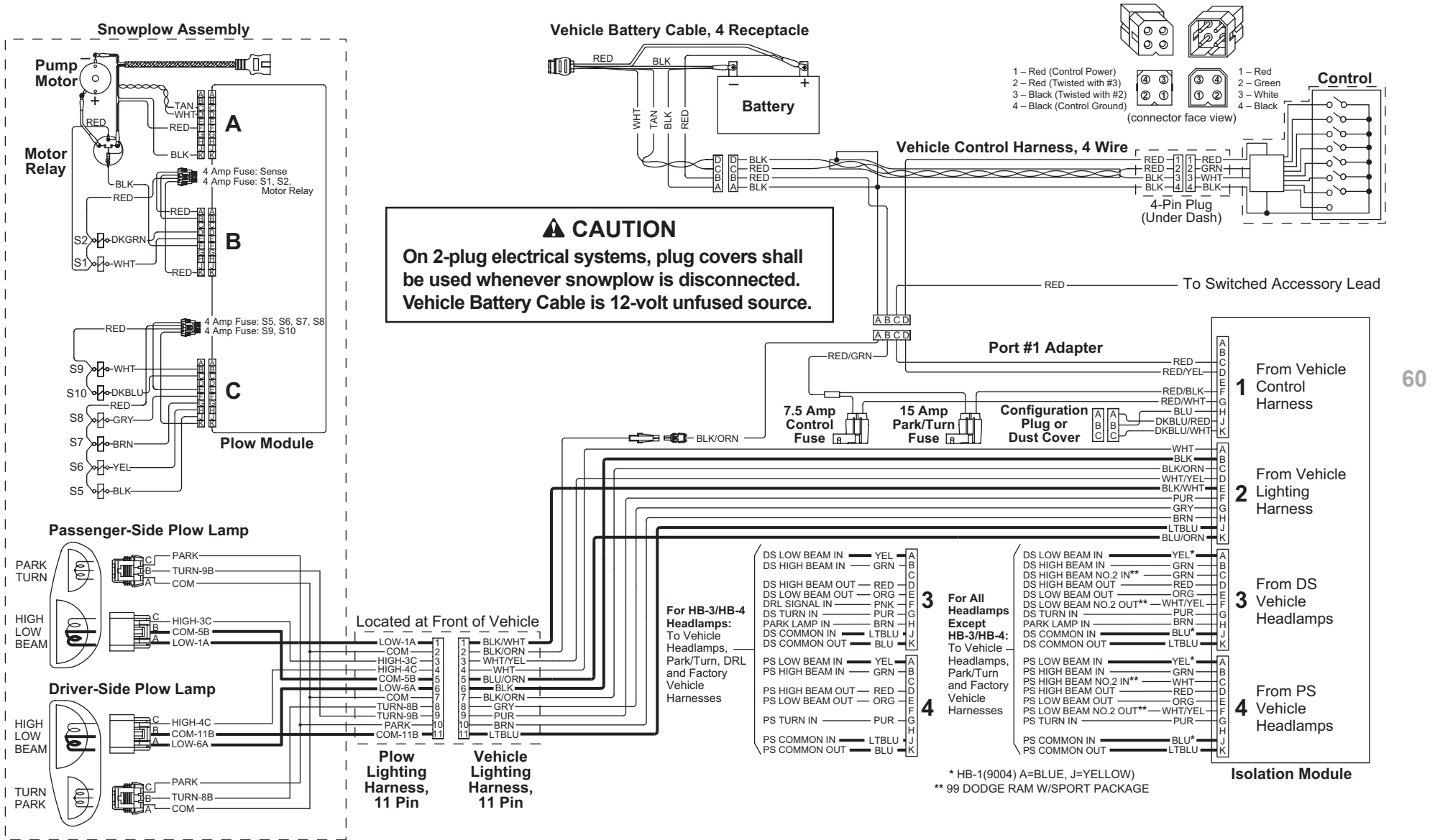

HIGH BEAM HEADLAMPS WITH SNOWPLOW CONNECTED TO VEHICLE (4-PORT MODULE)

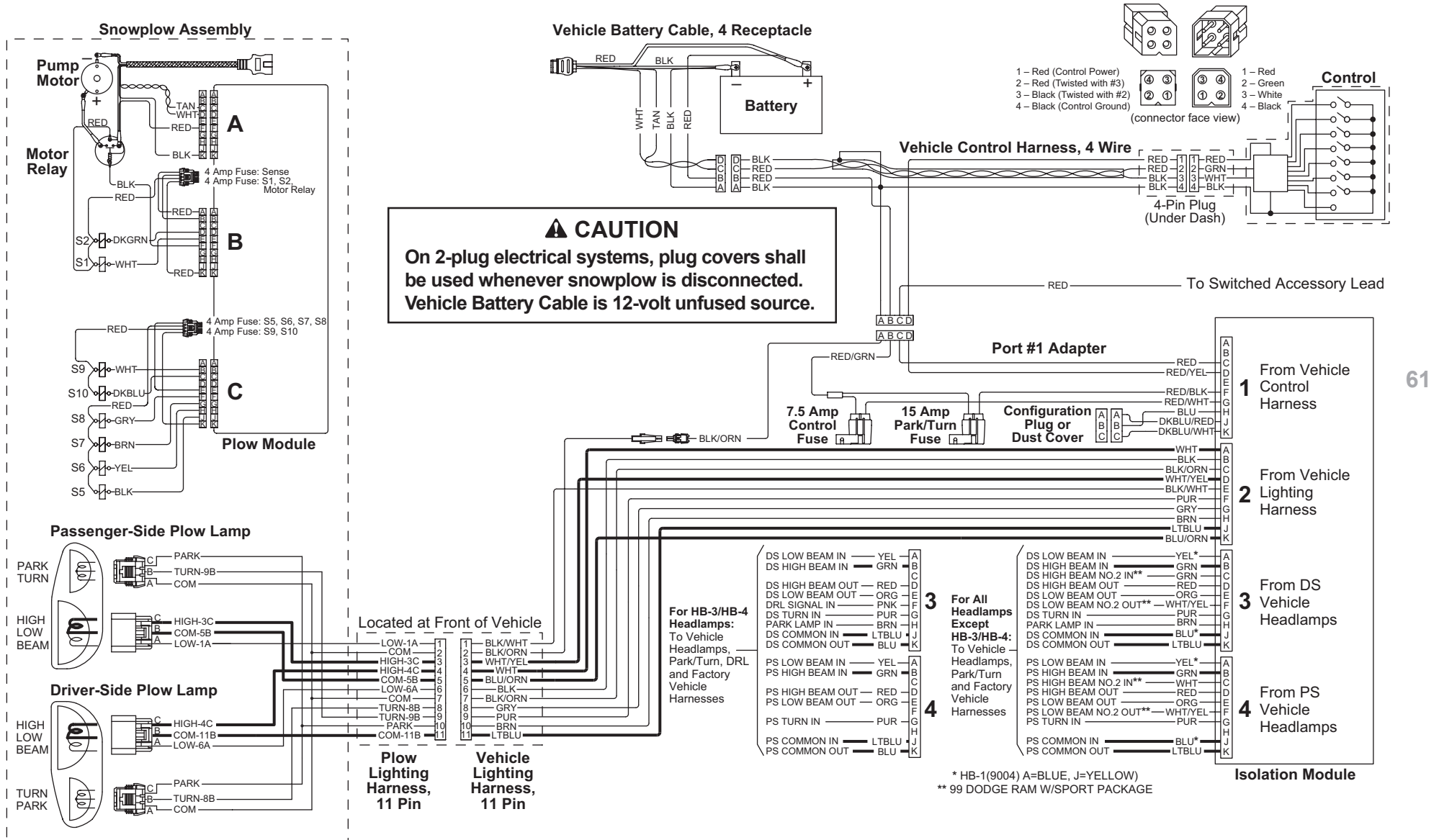

LOW BEAM HEADLAMPS WITH SNOWPLOW CONNECTED TO VEHICLE (3-PORT MODULE)

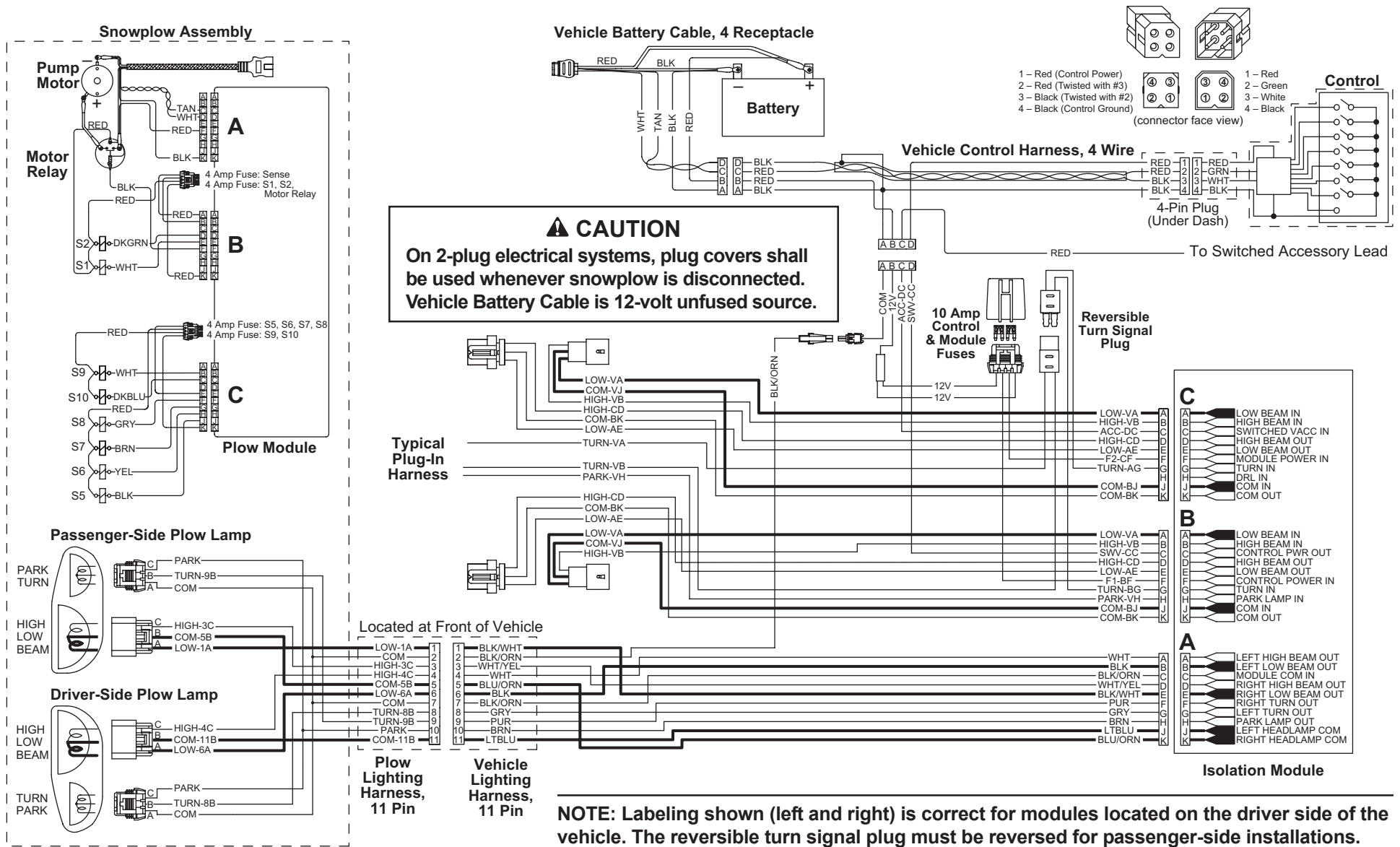

HIGH BEAM HEADLAMPS WITH SNOWPLOW CONNECTED TO VEHICLE (3-PORT MODULE)

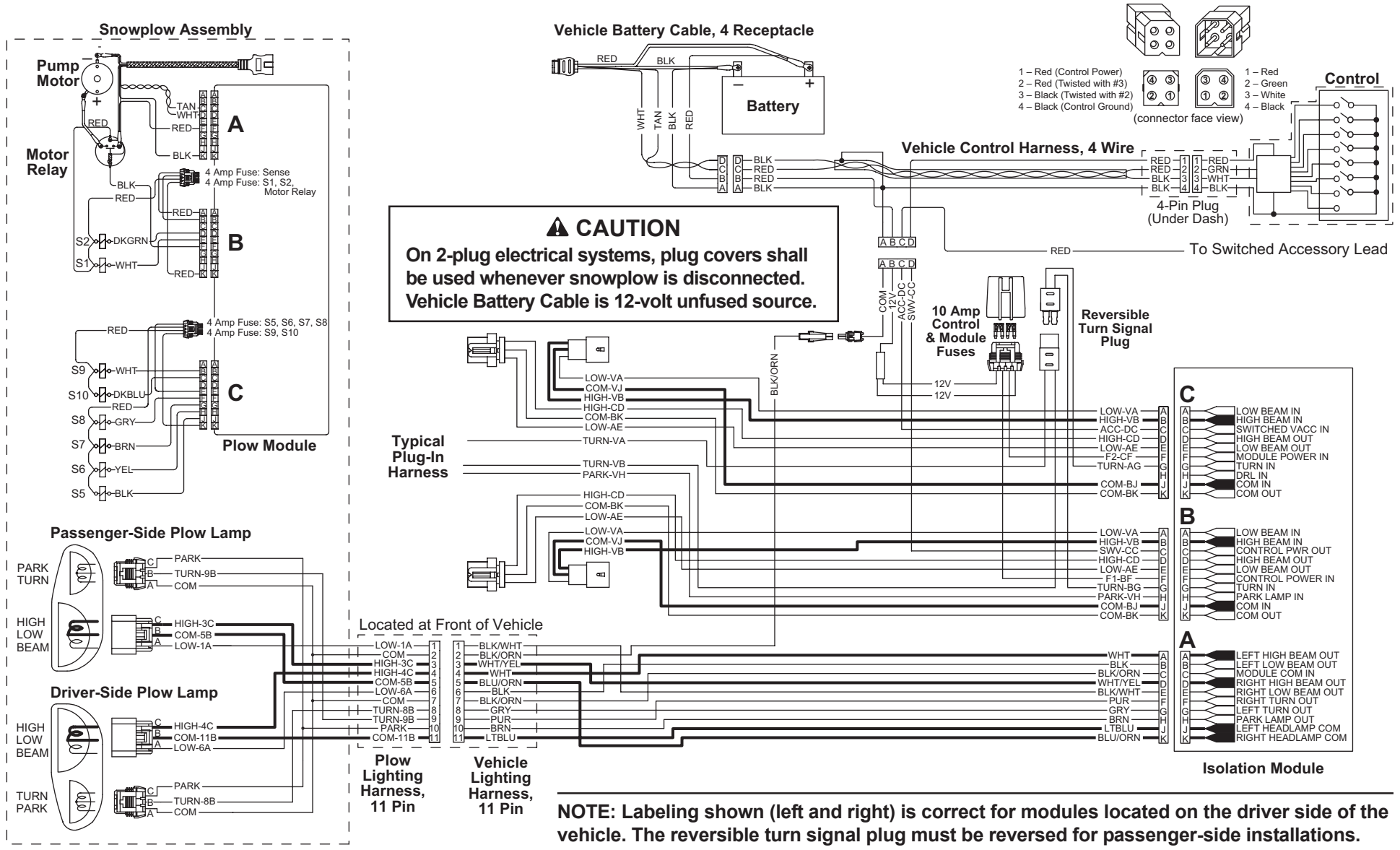

TROUBLESHOOTING GUIDE – TABLE OF CONTENTS

Introduction	65	Solenoid Coil Activation Test (SCAT)	71
How to Use the Troubleshooting Guide	65	Individual Solenoid Coil Test	73
Electrical Testing	65	Control/Cable/Plow Module Test	74
Before You Begin	66	Motor and Motor Relay Test	75
Headlamp Troubleshooting	67	Pump Pressure Test	76
Vehicle Headlamps	67	Relief Valve Inspection and Adjustment	77
Snowplow Headlamps	68	Notes	78
Snowplow Park/Turn Lamps	69		
Snowplow DRL Lamps	70		

TROUBLESHOOTING GUIDE

INTRODUCTION

All malfunctions of the XLS™ snowplow can be categorized as structural, electrical or hydraulic. Structural issues are generally related to the blade wings, A-frame, headgear and mount components and are usually identified by visual inspection. However, electrical and hydraulic issues can be difficult to trace.

Read and understand the Theory of Operation before attempting troubleshooting.

HOW TO USE THE TROUBLESHOOTING GUIDE

Because of the relative complexity of the XLS snowplow electrical and hydraulic systems, some conditions must be eliminated in order to develop valid tests.

If the listed conditions are not met, the procedure can result in inaccurate results and wasted time.

In many cases, satisfying the listed conditions alone solves the problem.

1. Go to the Before You Begin section (next page), and satisfy the listed conditions. These conditions **must** be met before proceeding to any of the tables and tests that follow.
2. If a lighting problem exists, proceed to the proper Headlamp Troubleshooting tables for a list of basic test questions and solutions to common problems.

3. If still having problems or the problem is not related to the headlamps, go to the Hydraulic System Testing Section.
4. Follow along sequentially through the tables and tests, referring to the Hydraulic & Electrical Schematics and System Overview sections as needed. Eventually the problem is identified at the component level.

ELECTRICAL TESTING

Read and understand the electrical circuit operation information in the Theory of Operation section. A simple 12-volt (12V) test light with a ground lead can be used for circuit testing in most cases. The exception is the paired multiplex wiring, which carries a low level signal from the control to the Plow Module. In this case, an ohmmeter may be used to check continuity.

When directed to check for 12V, ground the test lamp lead and probe the terminal. When asked to check for ground, attach the test lamp lead to +12V and probe the terminal.

NOTE: 12V is a nominal value. If using a voltmeter, actual voltage will vary with the vehicle and presence of loads in tested circuits. Continuity alone does not guarantee a good circuit. Poor connectors or damaged wires may have continuity but be unable to carry sufficient current.

TROUBLESHOOTING GUIDE

BEFORE YOU BEGIN

Before proceeding, or performing any tests, you *must* verify the following conditions:

1. **Verify** that the customer has accurately and completely described the problem. Check all lighting and snowplow functions.
 - c. The control is connected in the cab and turned ON. Verify that the control power LED is in a steady state and is not flashing.
2. Check the **obvious**:
 - a. Snowplow is attached to vehicle and all harnesses are connected.
 - b. Ignition is turned ON or engine is running if operating control from within the cab.
 - d. Fuses are good.
 - e. Vehicle battery and charging system are in good condition and battery connections are clean and tight.
 - f. Harness connector pins and terminals are free of corrosion, ensuring good connections, and coated with dielectric grease.

⚠ CAUTION
Fill the reservoir to the fill level only. Do not overfill. Overfilling could damage the unit.

⚠ CAUTION
Do not mix different types of hydraulic fluid. Some fluids are not compatible and may cause performance problems and product damage.

- g. Hydraulic reservoir is filled to proper level with recommended fluid when snowplow is in fully retracted position and lift ram is fully retracted. See Product Specifications.
- h. There are no fluid leaks from hoses, fittings, rams or the hydraulic unit.
- i. Hoses are routed correctly.
- j. Coil wire connections are secure and correct.
- k. Correct cartridges are installed in the proper locations.

TROUBLESHOOTING GUIDE

VEHICLE HEADLAMPS

Incorrect Operation or No Headlamps

	BASIC CHECK QUESTIONS	SOLUTIONS
1	DRL mode/automatic headlamp function	Fully understand OEM headlamp operation; refer to vehicle owner's manual.
2	Correct Isolation Module kit installed for application	Verify per eMatch at www.fisherplows.com .
3	OEM lights operating correctly prior to installation	OEM headlamps must be fully operational for correct Isolation Module operation.
4	OEM fuse tests good	Replace with proper fuse.
5	OEM headlamp bulb operational	Replace with proper bulb.
6	Plugged into OEM headlamp correctly	Connect per Isolation Module Installation Instructions.
7	Harnesses in correct location at Isolation Module and installed per Installation Instructions	Install using Isolation Module Installation Instructions.
8	Harnesses configured correctly for HB-1/HB-5 and/or kits using adapters	Install using Isolation Module Installation Instructions.
9	Configuration plug correct (only required on certain 4-Port Module installations)	Refer to Isolation Module Installation Instructions.
10	Correct harnesses and/or Isolation Module in kit	Refer to Isolation Module Parts List.
11	Harness wired per drawing	See electrical schematics in this guide.
12	Verify power and ground in proper pin locations at Isolation Module	See electrical schematics in this guide.
13	Verify power and ground in proper pin locations to vehicle headlamp	See electrical schematics in this guide.
14	Test Isolation Module with Isolation Module tester	Test using instructions supplied with tester.

TROUBLESHOOTING GUIDE

SNOWPLOW HEADLAMPS

Incorrect Operation or No Headlamps

	BASIC CHECK QUESTIONS	SOLUTIONS
1	DRL mode/automatic headlamp function	Fully understand OEM headlamp operation; refer to vehicle owner's manual.
2	Harnesses connected at vehicle and snowplow (all)	Harnesses must be connected for all snowplow and headlamp functions.
3	Corrosion at harness connectors	Replace as needed.
4	Ignition ON	Ignition switch or vehicle park lights must be ON for snowplow headlamps to operate.
5	Control powers up with key ON	Go to Control/Cable/Plow Module Test .
6	Correct Isolation Module kit installed for application	Verify per eMatch at www.fisherplows.com .
7	OEM lights operating correctly prior to installation	OEM headlamps must be fully operational for correct Isolation Module operation.
8	OEM fuse tests good	Replace with proper fuse.
9	Bulb burned out	Replace with proper bulb.
10	Plugged into OEM headlamp correctly	Connect per Isolation Module Installation Instructions.
11	Harnesses in correct location at Isolation Module and installed per Installation Instructions	Install using Isolation Module Installation Instructions.
12	Harnesses configured correctly for HB-1/HB-5 and/or kits using adapters	Install using Isolation Module Installation Instructions.
13	Configuration plug correct (only required on certain 4-Port Module installations)	Refer to Isolation Module Installation Instructions.
14	Correct harnesses and/or Isolation Module in kit	Refer to Isolation Module parts list.
15	Harness wired per drawing	See electrical schematics in this guide.
16	Verify power and ground in proper pin locations at Isolation Module	See electrical schematics in this guide.
17	Verify power and ground in proper pin locations to vehicle headlamp	See electrical schematics in this guide.
18	Test Isolation Module with Isolation Module tester	Test using instructions supplied with tester.

TROUBLESHOOTING GUIDE

SNOWPLOW PARK/TURN LAMPS*

Incorrect Operation or No Park/Turn Lamps

	BASIC CHECK QUESTIONS	SOLUTIONS
1	OEM park/turn lamps working	Refer to vehicle owner's manual for fuse location and size.
2	Harnesses connected at vehicle and snowplow (all)	Harnesses must be connected for all snowplow and headlamp functions.
3	Corrosion at harness connectors	Replace as needed.
4	Ignition ON	Ignition must be ON for snowplow turn lamps to operate.
5	Control powers up with key ON	Go to Control/Cable/Plow Module Test .
6	15-amp park/turn fuse good in #1 harness	Replace with proper fuse.
7	Black/orange "ground" wire connected to motor ground stud **	Refer to Isolation Module Installation Instructions.
8	Spliced into OEM park/turn circuit correctly	Refer to Isolation Module Installation Instructions.
9	Harnesses in correct location at Isolation Module and installed per Installation Instructions	Install using Isolation Module Installation Instructions.
10	Harness wired per drawing	See electrical schematics in this guide.
11	Verify power and ground in proper pin locations at Isolation Module	See electrical schematics in this guide.
12	Verify power and ground in proper pin locations to vehicle headlamp	See electrical schematics in this guide.
13	Bulb burned out	Replace with proper bulb.

* Some applications may use the turn circuit for DRLs.

** Not applicable to INTENSIFIRE™ headlamps.

TROUBLESHOOTING GUIDE

SNOWPLOW DRL LAMPS*

Incorrect Operation or No DRL Lamps

	BASIC CHECK QUESTIONS	SOLUTIONS
1	Fully understand OEM DRL operation	Refer to vehicle owner's manual for DRL operation.
2	OEM headlamps and DRLs operating correctly	OEM headlamps must be fully operational for correct Isolation Module operation.
3	OEM DRL fuse tests good	Refer to vehicle owner's manual for fuse location and size.
4	Harnesses connected at vehicle and snowplow (all)	Harnesses must be connected for all snowplow and headlamp functions.
5	Corrosion at harness connectors	Replace as needed.
6	Ignition ON	Ignition must be ON for snowplow DRL operation.
7	Does control power up with key ON	Go to Control/Cable/Plow Module Test .
8	Snowplow headlamp and park/turn lamps all working correctly	See electrical schematics in this guide.
9	Correct Isolation Module kit installed for application	Verify per eMatch at www.fisherplows.com .
10	Isolation Module and harnesses correctly installed per Installation Instructions	Refer to Isolation Module Installation Instructions.
11	Harness wired per drawing	See electrical schematics in this guide.
12	Bulb burned out	Replace with proper bulb.

70

* Snowplow DRLs operate as a series circuit and will illuminate bulb at 1/2 intensity. In some applications, the OEM DRLs will stay illuminated with snowplow attached.

TROUBLESHOOTING GUIDE

SOLENOID COIL ACTIVATION TEST (SCAT)

NOTE: See the System Overview – Controls section for details on control time-outs and wing functions.

The main purpose of the SCAT test is to narrow down a problem as either being electrical or hydraulic. Follow the steps below to diagnose the problem, then go to the appropriate test as directed.

1. Verify that harnesses B and C are properly attached to the solenoid coils. Refer to the labels on the hydraulic unit and the electrical schematics in this guide for details.
2. Install the Diagnostic Harness (PN 29290-1) according to the instructions on the following pages.
3. When instructed to do so, perform the SCAT test by activating the control for each function and checking for magnetic pull at all eight solenoid coils. A solenoid coil is magnetized if a screwdriver held nearby is attracted.

4. Compare the SCAT test results with the testing charts on the following pages.

If the motor relay LED is not activating when it should, go to the Motor and Motor Relay Test.

If a coil(s) is not magnetizing when it should be, you have an electrical problem. Connect a test light in series with the two connectors removed from the coil. Select any function on the control except LOWER. If the test light does not illuminate, determine if 12V is present on the red wire. If 12V is present, check for switched ground. If switched ground is present, go to the Individual Solenoid Coil Test. If switched ground is not present, go to the Control/Cable/Plow Module Test.

If the motor relay and all coils are working properly, you have a hydraulic problem. Go to the Hydraulic System Test.

Harness B Solenoid Coil Connections

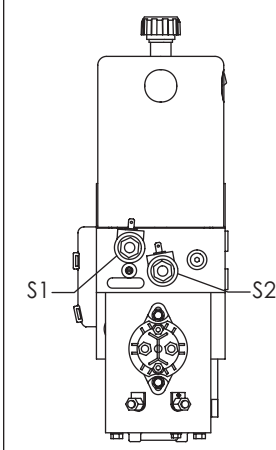

SOLENOID VALVE	S1	S2
VALVE TYPE	SVCV08-20	SV08-2004
WIRE COLORS	WHITE RED	GREEN RED
MODULE CONNECTION	← PORT B →	
TORQUE SPECIFICATIONS		
ALL SOLENOID VALVES:	19-21 FT-LB	
ALL SOLENOID COIL NUTS:	48-60 IN LB	
MOTOR RELAY TERMINALS:	SMALL 10-15 IN-LB LARGE 25-35 IN-LB	
MOTOR TERMINALS:	50-60 IN-LB	

44904

Harness C Solenoid Coil Connections

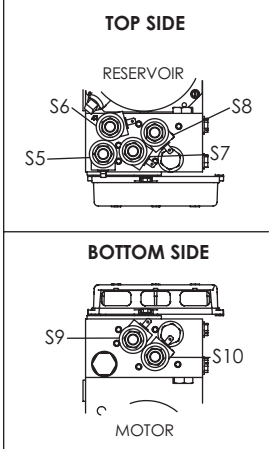

SOLENOID VALVE	S5	S6	S7	S8
VALVE TYPE	SV08-45	SV08-41	SV08-30	SV08-30
WIRE COLORS	BLACK RED	YELLOW RED	BROWN RED	GRAY RED
SOLENOID VALVE	S9	S10		
VALVE TYPE	SV08-30	SV08-30		
WIRE COLORS	WHITE RED	BLUE RED		
MODULE CONNECTION	← PORT C →			
TORQUE SPECIFICATIONS				
ALL SOLENOID VALVES:	19-21 FT-LB			
ALL SOLENOID COIL NUTS:	48-60 IN-LB			

44906

TROUBLESHOOTING GUIDE

SOLENOID COIL ACTIVATION TEST (SCAT)

NOTE: This diagnostic harness kit can be used with or without the snowplow connected to a vehicle. Follow the appropriate instructions for each testing situation.

⚠ WARNING

Lower blade when vehicle is parked. Temperature changes could change hydraulic pressure, causing the blade to drop unexpectedly or damaging hydraulic components. Failure to do this could result in serious personal injury.

On-Truck Testing

Remove the vehicle ignition key and put the vehicle in park or in gear to prevent others from starting the vehicle during testing.

1. Disconnect the snowplow and vehicle battery cables, then remove the hydraulic unit covers.
2. Remove the short red cable from the motor relay.
3. Unplug the snowplow connectors from Ports A and B of the Plow Module.

4. Connect the diagnostic harness connectors A and B to the matching ports on the Plow Module (A to A and B to B).

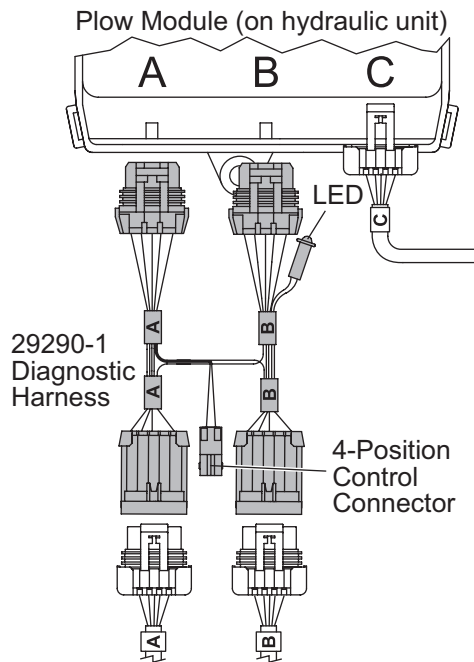

5. Plug the connectors removed from the Plow Module into the matching connectors on the diagnostic harness (A to A and B to B).
6. Connect the snowplow control to the 4-position control connector either in the cab of the vehicle or on the diagnostic harness.

7. Reconnect the snowplow and vehicle battery cables. Do not connect the short cable assembly at this time.

NOTE: If you connect the control inside the cab of the vehicle, the engine does not need to be running, but the vehicle ignition key must be turned to the "ON" position before proceeding. If you connect the control to the diagnostic harness, the key should be left out of the ignition.

8. Turn the snowplow control ON and perform a Solenoid Coil Activation Test (SCAT). See the chart below for solenoid numbers and functions.

Solenoid Coil Activation Test (SCAT) Chart	
Control Function	Component(s) Activated
Raise	S1, Motor Relay
Lower	S2
Angle Right	S5, Motor Relay
Angle Left	S6, Motor Relay
Scoop	S8, S10, Motor Relay
Retract	S7, S9, Motor Relay
Wing (Right – Out)	S10, Motor Relay
Wing (Right – In)	S9, Motor Relay
Wing (Left – Out)	S8, Motor Relay
Wing (Left – In)	S7, Motor Relay

NOTE: The green LED on the diagnostic harness will illuminate when the motor relay function is activated. This light only tests the Plow Module's motor relay output. Refer to a Mechanic's Guide for instructions on properly testing a motor relay.

9. After completing the SCAT test, turn the snowplow control and the vehicle ignition OFF, then disconnect the snowplow and vehicle battery cables.
10. Perform any required repairs and retest as needed. Always disconnect the snowplow and vehicle battery cables before removing the diagnostic harness.
11. Reconnect the short red cable assembly to the motor relay.

Excerpts taken from Diagnostic Harness Kit Installation Instructions (Lit. No. 29289, Rev. 03).

TROUBLESHOOTING GUIDE

SOLENOID COIL ACTIVATION TEST (SCAT)

Off-Truck Testing

1. Remove the hydraulic unit covers.
2. Remove the short red cable from the motor relay.
3. Unplug the snowplow connectors from Ports A and B of the Plow Module.
4. Connect the diagnostic harness connectors A and B to the matching ports on the Plow Module (A to A and B to B).

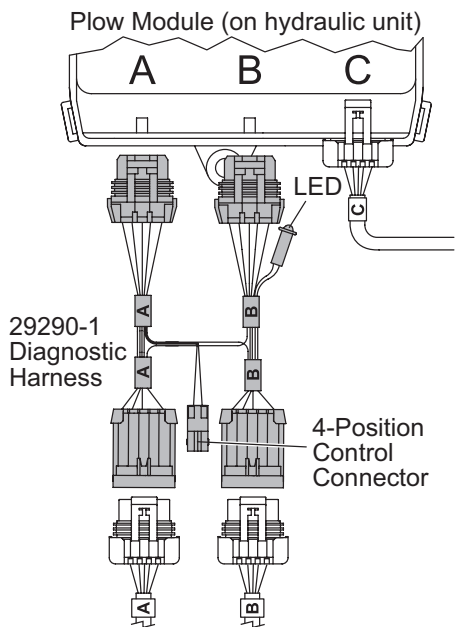

5. Plug the connectors removed from the Plow Module into the matching connectors on the diagnostic harness (A to A and B to B).
6. Connect the snowplow control into the 4-position control connector on the diagnostic harness.
7. Connect a 12V power source to the snowplow battery cable (POSITIVE [+] 12V to the red wire and NEGATIVE [-] to the black wire). Turn ON the power source.
8. Turn the snowplow control ON and perform a Solenoid Coil Activation Test (SCAT). See the chart below for solenoid numbers and functions.

Solenoid Coil Activation Test (SCAT) Chart	
Control Function	Component(s) Activated
Raise	S1, Motor Relay
Lower	S2
Angle Right	S5, Motor Relay
Angle Left	S6, Motor Relay
Scoop	S8, S10, Motor Relay
Retract	S7, S9, Motor Relay
Wing (Right – Out)	S10, Motor Relay
Wing (Right – In)	S9, Motor Relay
Wing (Left – Out)	S8, Motor Relay
Wing (Left – In)	S7, Motor Relay

NOTE: The green LED on the diagnostic harness will illuminate when the motor relay function is activated. This light only tests the Plow Module's motor relay output.

9. After completing the SCAT test, turn the snowplow control OFF and disconnect the power source.
10. Perform any required repairs and retest as needed. Always disconnect the snowplow and vehicle battery cables before removing the diagnostic harness.
11. Reconnect the short red cable assembly to the motor relay.

INDIVIDUAL SOLENOID COIL TEST

1. Remove both wires from coil terminals.
2. Attach an ohmmeter across the coil terminals.
3. A reading that is not approximately 7 ohms indicates coil is damaged and must be replaced.
4. Attach an ohmmeter to one coil terminal and to the steel washer at the end of the coil.
5. A reading that is not "open" indicates that the coil has internal shorts and needs to be replaced.
6. If both readings are OK (i.e., approximately 7 ohms across terminals *and* "open" between terminal and washer), then the coil is good.

NOTE: A good coil will draw approximately 1.5 amps.

Excerpts taken from Diagnostic Harness Kit Installation Instructions (Lit. No. 29289, Rev. 03).

TROUBLESHOOTING GUIDE

CONTROL/CABLE/PLOW MODULE TEST

CONDITION	POSSIBLE CAUSE	CORRECTIVE ACTION
Control power light is not ON.	Snowplow is not connected	<ul style="list-style-type: none"> • Make sure grille plugs between snowplow and truck are properly connected.
	Incomplete harness connection(s) or damaged harness(es)	<ul style="list-style-type: none"> • With the vehicle switched accessory ON, test the 4-pin connector inside the cab. If pin 1 does not have 12V and/or if pin 4 does not have ground, use the electrical schematic in this guide to trace the wires from the connector back to their source. Look for incomplete connections or damaged wires. Complete connections or repair/replace damaged wires and harnesses as needed.
	Single-pin connector on vehicle lighting harness is not connected	<ul style="list-style-type: none"> • Make sure single-pin connector on vehicle lighting harness is properly connected.
	Harnesses connected to Isolation Module incorrectly	<ul style="list-style-type: none"> • Using the electrical schematic in this guide, verify that Isolation Module and harnesses are properly connected.
	Control fuse is blown	<ul style="list-style-type: none"> • Replace all blown fuses in under-hood electrical harnesses.
Control power light is blinking.	Poor connection, Damaged control or Damaged Plow Module	<ul style="list-style-type: none"> • Make sure all plugs (control, between the snowplow and truck, on the snowplow, etc.) are properly connected. • If all plugs are properly connected, install a properly working control. If problem is corrected, replace PC board and/or coiled cord in damaged control. • If problem is not corrected with properly working control, replace Plow Module.
Control power light is ON, but snowplow does not respond.	Harnesses connected to Isolation Module incorrectly	<ul style="list-style-type: none"> • Using the electrical schematic in this guide, verify that Isolation Module and harnesses are properly connected.
	Blown fuse or Damaged Plow Module	<ul style="list-style-type: none"> • Replace all blown fuses on truck and snowplow. • If fuses are all okay, check for 12V at all coils and primary terminal of motor relay. If 12V is missing from any coil or relay, replace Plow Module. If 12V is present, go to next Possible Cause.
	Damaged harness(es) or cable(s)	<ul style="list-style-type: none"> • Perform a Solenoid Coil Activation Test (SCAT) according to the instructions in this guide. Replace/repair any damaged harnesses and cables.
	Damaged control or Plow Module	<ul style="list-style-type: none"> • Install a properly working control. If problem is corrected, replace PC board and/or coiled cord in damaged control. • If problem is not corrected with properly working control, replace Plow Module.

74

To Safely Handle PCB:

⚠ CAUTION
Circuit board may be damaged by static electricity. Always touch ground before handling PC board.

Before disassembling control and touching the PC board, be sure to remove any static charge from yourself. Static charge can build up as a technician works on the control. Best practice is to work at a properly grounded work station with a

grounded wrist strap attached to the technician. In place of proper work station, the technician should work in an oil and solvent free area and touch a good ground each time before touching the PC board while servicing the unit.

Handle the PC board by the edges only.

Do not touch the carbon (black) areas of the keypad. Your skin oils will deteriorate the contact area.

TROUBLESHOOTING GUIDE

MOTOR AND MOTOR RELAY TEST

⚠ WARNING

Keep 8' clear of the blade when it is being raised, lowered or angled. Do not stand between the vehicle and blade or directly in front of the blade. If the blade hits or drops on you, you could be seriously injured.

Perform this test if the control lights up and turns ON, but the motor does not run when any function but LOWER is selected.

1. Check the F2 fuse on harness B. Replace if fuse is blown, then retest snowplow.
2. Remove the 8" red battery cable from the large terminal of the motor relay and isolate it. Isolating the battery cable will

eliminate the potential of accidental blade movement during testing.

3. Check for 12V at the small terminal of the motor relay with the red wire attached to it. If 12V is not present, recheck the coil fuse F2 in harness B. If the fuse is good, check the red wire and harness B. Replace/repair either the wire or the harness as needed.

4. If 12V is present at the small relay terminal with the red wire, turn the control ON, then check for switched ground on the small terminal with the black wire attached to it while activating any function except LOWER. If switched ground is not present, check the black wire and harness B of the Plow Module. Replace/repair either the wire or the harness as needed.
5. Check for switched 12V at the empty large motor relay terminal while activating any control function except LOWER. The empty terminal is the terminal that would normally contain the 8" red battery cable. If switched 12V is not present, replace the motor relay.
6. If switched 12V is present at the empty large motor relay terminal, replace the motor.
7. Once testing is complete, reinstall the 8" red battery cable, then retest snowplow.

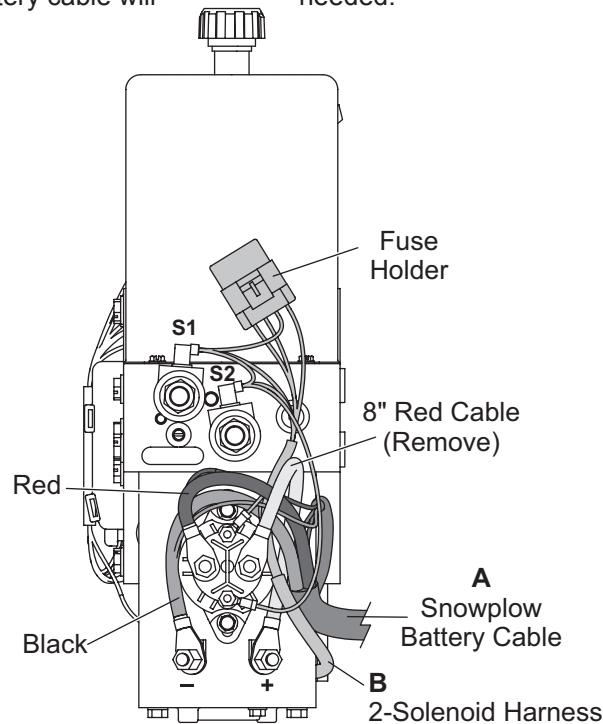
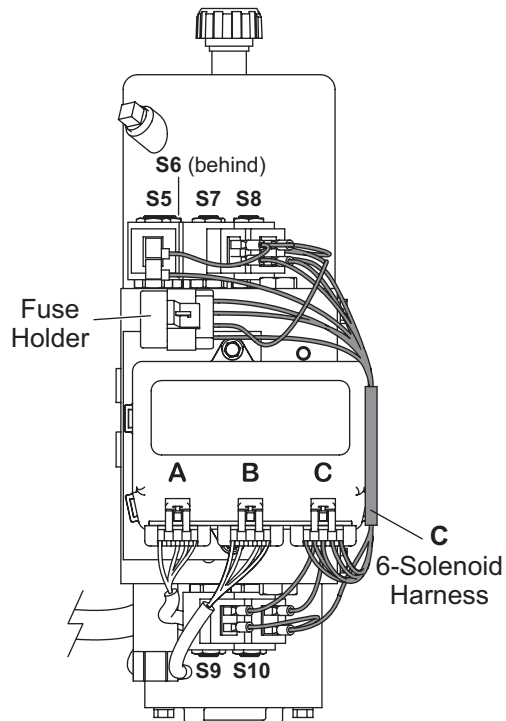

* See wire stamping for fuse identification.

TROUBLESHOOTING GUIDE

PUMP PRESSURE TEST

NOTE: Reservoir will contain residual pressure. Remove, then reinstall, breather to release pressure before proceeding.

1. Verify proper fluid level before beginning test.
2. Attach a 3000 psi hydraulic pressure gauge to pressure test port as shown in the illustration.
3. Activate the ANGLE function either left or right until blade is fully angled.

NOTE: Control will time out after 3.25 seconds. Repeat command if blade is not fully angled.

4. Repeat the ANGLE function, and read the pressure shown on the gauge.
5. Refer to the following table.

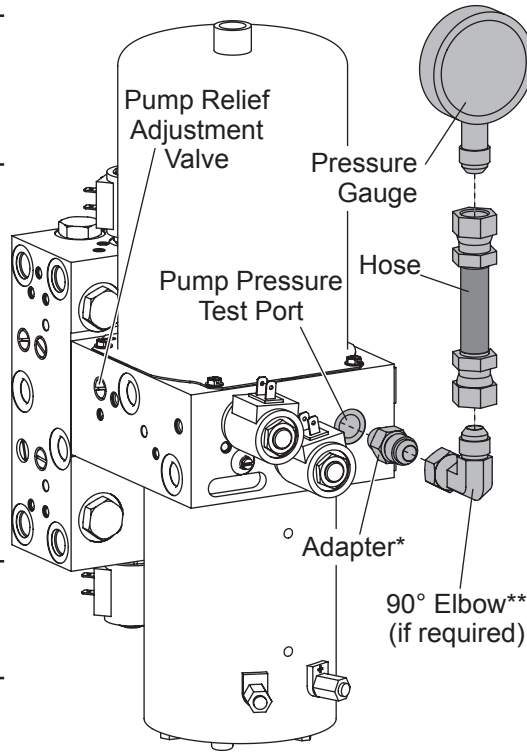

BLADE MOVEMENT		ANGLE RIGHT	ANGLE LEFT
MOTOR	M	ON	ON

CONDITION	POSSIBLE CAUSE	CORRECTIVE ACTION
Pump pressure is below 2250 ± 50 psi.	Pump Relief Valve	<ul style="list-style-type: none"> • Pump relief valve may be out of adjustment. Turn relief valve clockwise 1/4 turn and retest pressure. Repeat until correct pressure (2250 ± 50 psi) is obtained. • If correct pressure is not obtained after readjustment, remove and inspect the relief valve and its components. Check O-ring, stem and ball for wear or damage. Reseat ball or replace relief valve as needed. Reinstall/replace and readjust valve, then retest pump pressure.
	O-Ring (between pump and valve block)	<ul style="list-style-type: none"> • Remove the pump and inspect the O-ring between the pump and the valve block for wear or damage. Reinstall/replace O-ring and pump, then retest pump pressure.
	Pump	<ul style="list-style-type: none"> • Remove the pump and inspect it for wear or broken gears. Replace pump if needed, adjust pump relief valve, then retest pressure.
Motor draws more than 265 amps at pump relief.	Motor	<ul style="list-style-type: none"> • Replace the motor.

NOTE: See the following page for Relief Valve Inspection and Adjustment instructions.

* Straight Adapter (-6 JIC 37° Male Flare to -4 SAE O-Ring Boss Port) not included in 56679 Pressure Test Kit. (Parker PN 6-4 F50X)

** 90° Elbow (-6 JIC 37° Female Swivel to -6 JIC 37° Male Flare) not included in 56679 Pressure Test Kit. (Parker PN 6 C6X)

TROUBLESHOOTING GUIDE

RELIEF VALVE INSPECTION AND ADJUSTMENT

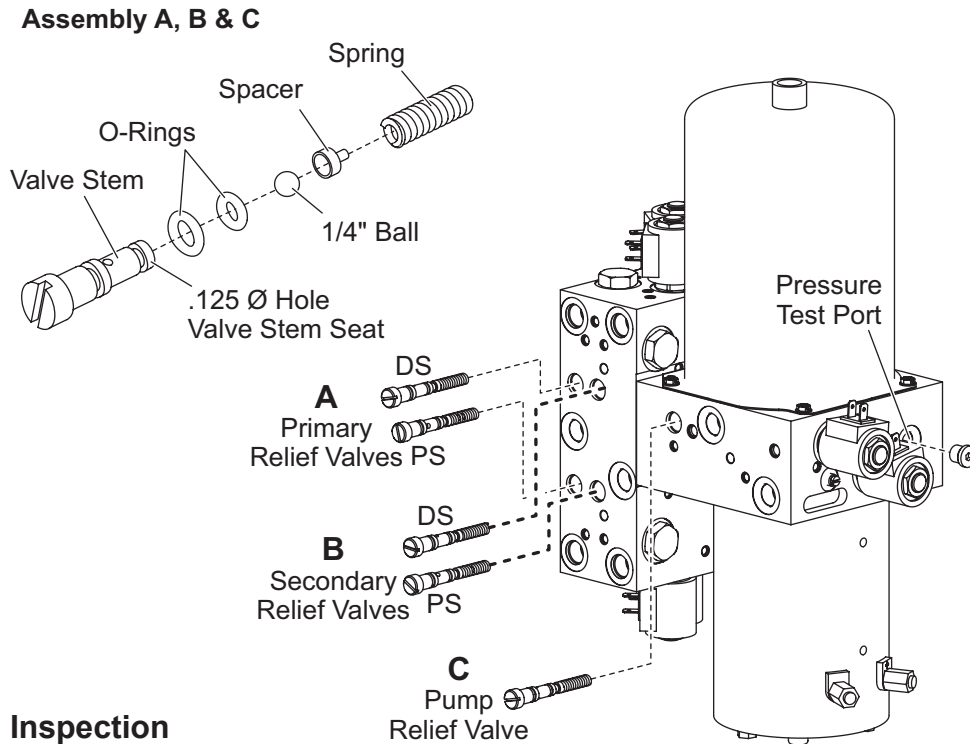

Inspection

1. Remove the valve stem, ball, spacer and spring.
2. Look for broken or damaged parts, contamination or missing or damaged O-rings.
3. If the parts are OK, place the ball on a hard wood block, hold the stem seat on the ball and lightly strike the top of the stem with a hammer. This will seat the ball and valve stem.
4. Apply a light coat of anti-seize or grease to stem threads. Lubricate O-rings with hydraulic fluid. Reassemble components into valve block.

⚠ CAUTION
Be careful to strike stem squarely. You can bend stem if you do not strike it squarely.

Adjustment

⚠ CAUTION
Never operate the unit while adjusting the relief valve. Doing so will damage the relief valve O-rings.

For the Pump Relief Valve (C):

1. Screw stem in until spring is fully compressed.
2. Back out (counterclockwise) the number of turns in the following chart.

Relief Valve	Approx. Pressure (psi)	# of Turns Out (ccw) from Fully Seated
A (Qty 2)	1500	†
B (Qty 2)	1700	†
C (Qty 1)	2250*	2-1/2

* See the Pump Pressure Test Section for details.

† See the following steps for the Wing Relief Valve Adjustment procedure.

For the Wing Relief Valves (A & B):

1. Install 3000 psi gauge into pressure test port or tee into base end hose of cylinder for the side being tested.
2. Turn RV2 (A-DS) or RV3 (A-PS) all the way in.
3. Fully extend wing and read pressure at deadhead. Do not adjust when pump is running.
4. Adjust RV1 (B-DS) or RV4 (B-PS) so gauge reads 1700 ± 50 psi.
5. Adjust RV2 (A-DS) or RV3 (A-PS) so gauge reads 1500 ± 50 psi.



Fisher Engineering
50 Gordon Drive
Rockland, ME 04841
www.fisherplows.com

DD A SUBSIDIARY OF DOUGLAS DYNAMICS, L.L.C.

Copyright © 2007 Douglas Dynamics, L.L.C. All rights reserved. This material may not be reproduced or copied, in whole or in part, in any printed, mechanical, electronic, film or other distribution and storage media, without the written consent of Fisher Engineering. Authorization to photocopy items for internal or personal use by Fisher Engineering outlets or snowplow owner is granted.

Fisher Engineering reserves the right under its product improvement policy to change construction or design details and furnish equipment when so altered without reference to illustrations or specifications used. Fisher Engineering or the vehicle manufacturer may require or recommend optional equipment for snow removal. Do not exceed vehicle ratings with a snowplow. This product is manufactured under the following US patents: 4,999,935; 5,353,530; 5,420,480; 5,638,618; 5,899,007; 6,253,470; 6,408,549; 6,944,978; RE 35,700; CAN patent 2,060,425; 2,184,922; 2,229,783; 2,356,036 and other patents pending. Fisher Engineering offers a limited warranty for all snowplows and accessories. See separately printed page for this important information. The following are registered (®) or unregistered (™) trademarks of Douglas Dynamics, L.L.C.: FISHER®, Fish-Stik®, Insta-Act®, INTENSIFIRE™, Minute Mount® 2, XLS™.

Printed in U.S.A.